



RT-400PP MANUAL



READ ALL INSTRUCTIONS BEFORE INSTALLING AND USING THIS APPLIANCE

Please read this entire manual before installation and use of this pellet fuel-burning appliance. Failure to follow these instructions could result in property damage, bodily injury, or even death. Contact local building or fire officials about restrictions and installation inspection requirements in your area. Save these instructions.

**A MAJOR CAUSE OF FIRES IS FAILURE TO
MAINTAIN REQUIRED CLEARANCES (AIR
SPACES) TO COMBUSTIBLE MATERIALS. IT IS
OF UTMOST IMPORTANCE THAT THIS
PRODUCT BE INSTALLED IN ACCORDANCE
WITH THESE INSTRUCTIONS.**



WARNING & SAFETY INFORMATION



READ ALL WARNING AND SAFETY INFORMATION BEFORE OPERATING GRILL

FOR OUTDOOR USE ONLY

NEVER ATTEMPT TO EMPTY, CLEAR, DISPOSE, OR REMOVE ASHES WHILE GRILL IS HOT. IF YOUR GRILL IS EQUIPPED WITH AN ASH CLEARING LEVER, DO NOT MOVE LEVER UNTIL GRILL IS COMPLETELY COOL

DO NOT STORE OR USE COMBUSTIBLE MATERIALS IN OR NEAR THIS APPLIANCE

NEVER TOUCH OR ATTEMPT TO MOVE GRILL WHILE HOT OR WITHOUT ASSISTANCE

NEVER MOVE YOUR GRILL WHILE IN OPERATION AND ALWAYS LOCK/SECURE WHEELS

YOUR RECTEQ GETS VERY HOT. USE HEAT RESISTANT GLOVES FOR OPENING/CLOSING LID, ESPECIALLY AT TEMPERATURES ABOVE 400°

KEEP CHILDREN AND PETS AWAY WHILE GRILL IS HOT. USE EXTREME CAUTION WHEN COOKING AT ALL TEMPERATURES

TO PREVENT FLARE UPS, CLEAN/REMOVE RESIDUAL GREASE FROM DRIP PANS, GRATES, AND BOTTOM OF GRILL REGULARLY. ESPECIALLY PRIOR TO COOKING ABOVE 350°F

IF NECESSARY, USE 14-GAUGE OR HEAVIER EXTENSION CORD THAT'S RATED FOR OUTDOOR USE

ALWAYS UNPLUG WHILE NOT IN USE

NEVER STORE ANY GRILL IN A SMALL SPACE OR PLACE IN A VEHICLE UNLESS COMPLETELY COOL AND FIRE IS VERIFIED AS EXTINGUISHED

LEAVE A MINIMUM OF 18" CLEARANCE FROM THE UNIT TO COMBUSTIBLE CONSTRUCTION AND/OR MATERIALS AT THE REAR, SIDES, AND TOP

USE ON LEVEL GROUND AND NEVER USE UNDER COMBUSTIBLE CEILINGS OR OVERHANGS

NEVER USE ON A COMBUSTIBLE FLOOR. USE ON A NONCOMBUSTIBLE FLOOR OR FLOOR PROTECTED WITH NONCOMBUSTIBLE SURFACE WHERE PROTECTIVE SURFACE HAS BEEN APPROVED FOR SUCH USE BY THE AUTHORITY HAVING JURISDICTION



WARNING & SAFETY INFORMATION



READ ALL WARNINGS AND SAFETY INFORMATION BEFORE OPERATING GRILL

NEVER PLUG IN YOUR GRILL WITHOUT ALL SERVICE ACCESS GRATES/PANELS INSTALLED AND ALWAYS PLUG INTO PROPERLY GROUNDED OUTLET (GFCI)

OCCASIONALLY, YOUR FIRE POT, VENTS/SMOKESTACKS SHOULD BE INSPECTED FOR OBSTRUCTIONS TO MAKE SURE PROPER AIRFLOW AND PROPER VENTILATION IS MAINTAINED

USE HEAT-RESISTANT MITTS OR GLOVES WHEN HANDLING FOOD, PANS, GRATES, ETC. WHILE OPERATING THIS UNIT. LONG HANDLED, NON-PLASTIC UTENSILS ARE ALSO RECOMMENDED

BE AWARE OF AND/OR REMOVE LOOSE CLOTHING, JEWELRY, AND ACCESSORIES BEFORE USING GRILL

BEFORE COVERING YOUR GRILL, MAKE SURE THAT THE GRILL HAS COOLED COMPLETELY

NEVER PUT YOUR HAND IN THE PELLET HOPPER OR ATTEMPT TO SERVICE ANY PART OF YOUR GRILL WHILE YOUR GRILL IS PLUGGED IN. KEEP ALL PROTECTIVE GUARDS IN PLACE

CARBON MONOXIDE WARNING:

FOLLOW THESE GUIDELINES TO PREVENT THIS COLORLESS, ODORLESS GAS FROM POISONING YOU, YOUR FAMILY, OR OTHERS.

KNOW THE SYMPTOMS OF CARBON MONOXIDE POISONING: HEADACHE, DIZZINESS, WEAKNESS, NAUSEA, VOMITING, SLEEPINESS, AND CONFUSION. CARBON MONOXIDE REDUCES THE BLOOD'S ABILITY TO CARRY OXYGEN. LOW BLOOD OXYGEN LEVELS CAN RESULT IN LOSS OF CONSCIOUSNESS AND DEATH.

SEE A DOCTOR IF YOU OR OTHERS DEVELOP COLD OR FLU-LIKE SYMPTOMS WHILE COOKING ON OR IN THE VICINITY OF THIS APPLIANCE. CARBON MONOXIDE POISONING, WHICH CAN EASILY BE MISTAKEN FOR A COLD OR FLU, IS OFTEN DETECTED TOO LATE.

ALCOHOL CONSUMPTION AND DRUG USE INCREASE THE EFFECTS OF CARBON MONOXIDE POISONING.

CARBON MONOXIDE IS ESPECIALLY TOXIC TO MOTHER AND CHILD DURING PREGNANCY, INFANTS, THE ELDERLY, SMOKERS, AND PEOPLE WITH BLOOD OR CIRCULATORY SYSTEM PROBLEMS, SUCH AS ANEMIA, OR HEART DISEASE.

Welcome to the recteq family!

Congratulations on the purchase of your new recteq wood fired pellet grill. With proper care and maintenance, your recteq will provide you years of trouble-free operation. Please review the following information carefully for useful tips and information that will help you utilize your grill's extensive features and benefits.

To see our favorite recipes and cooking tips, visit recteq.com. As you become familiar with your recteq, you will find that indoor cooking becomes the exception and not the rule in your house. With the ability to easily cook foods that meet or often exceed restaurant quality, you will no longer want to dine out and pay for food that does not live up to the recteq standard. Also, don't be alarmed when your neighbors call and ask if you will 'recteq' some meat for them...This is a common occurrence among recteq owners.

We invite you to join the vibrant and growing recteq social media community. Whether you want to contribute your own tips and recipes, learn from others, or a bit of both, please jump right in. You now have an incredible tool for cooking. Let's see how you use it!

Thank you for choosing recteq.

Ray Carnes & Ron Cundy Co-Founders, recteq, LLC

A handwritten signature in black ink that reads "Ray Carnes". The signature is fluid and cursive, with the first name "Ray" being more prominent than the last name "Carnes".A handwritten signature in black ink that reads "Ron Cundy". The signature is fluid and cursive, with the first name "Ron" being more prominent than the last name "Cundy".

CONTENTS

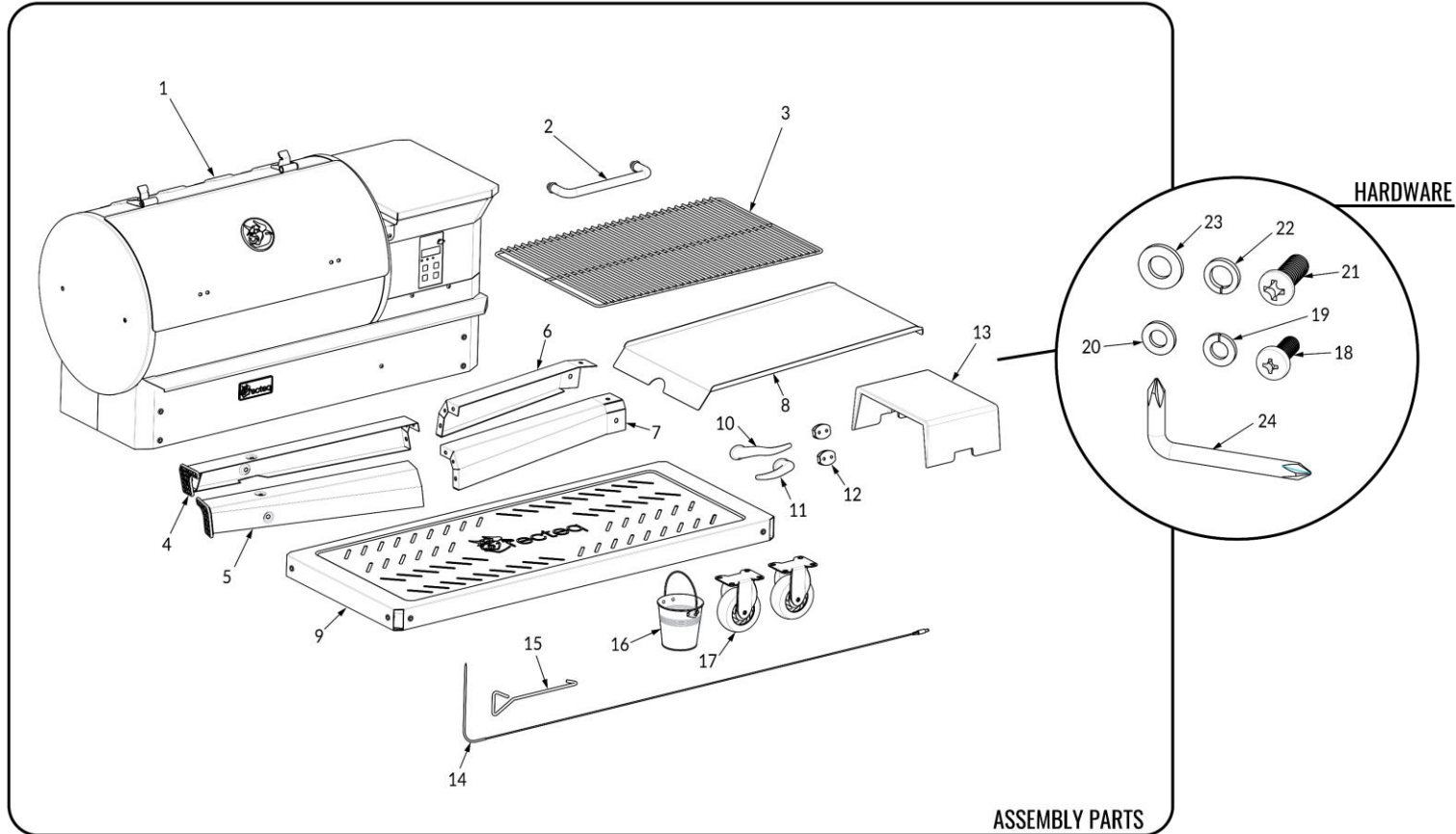

- | | |
|----------------------------|------------------------------|
| 1. Grill Body | 15. Grate Puller |
| 2. Pull-bar | 16. Drip Bucket |
| 3. Grill-Grate | 17. Fixed Wheels |
| 4. Back Left Leg | 18. Small Leg Bolt |
| 5. Front Left Leg | 19. Small Leg Lock Washer |
| 6. Rear Right Leg | 20. Small Leg Flat Washer |
| 7. Front Right Leg | 21. Medium Wheel Bolt |
| 8. Drip Pan | 22. Medium Wheel Lock Washer |
| 9. Bottom Shelf | 23. Medium Wheel Flat Washer |
| 10. Left Bull Horn Handle | |
| 11. Right Bull horn Handle | |
| 12. Bull-Horn Bracket | |
| 13. Cast Iron Deflector | |
| 14. Meat Probe | |

ASSEMBLY

Step 1: Unpack and Prepare for Assembly

Remove and unwrap all items from grill body.

With assistance, lay grill body on back using packing material to protect from damage. Be aware of sharp edges and points while assembling. Ensure grill is on level ground before beginning assembly.

Step 2: Attach Legs

Start with grill on its back. Attach each leg (items #4, #5, #6 and #7) to all four corners of the grill body using 3 small bolts, lock washers and flat washers (items #18, #19, and #20) for each leg (see diagram).

Hand-tighten all bolts before tightening with screwdriver or drill.

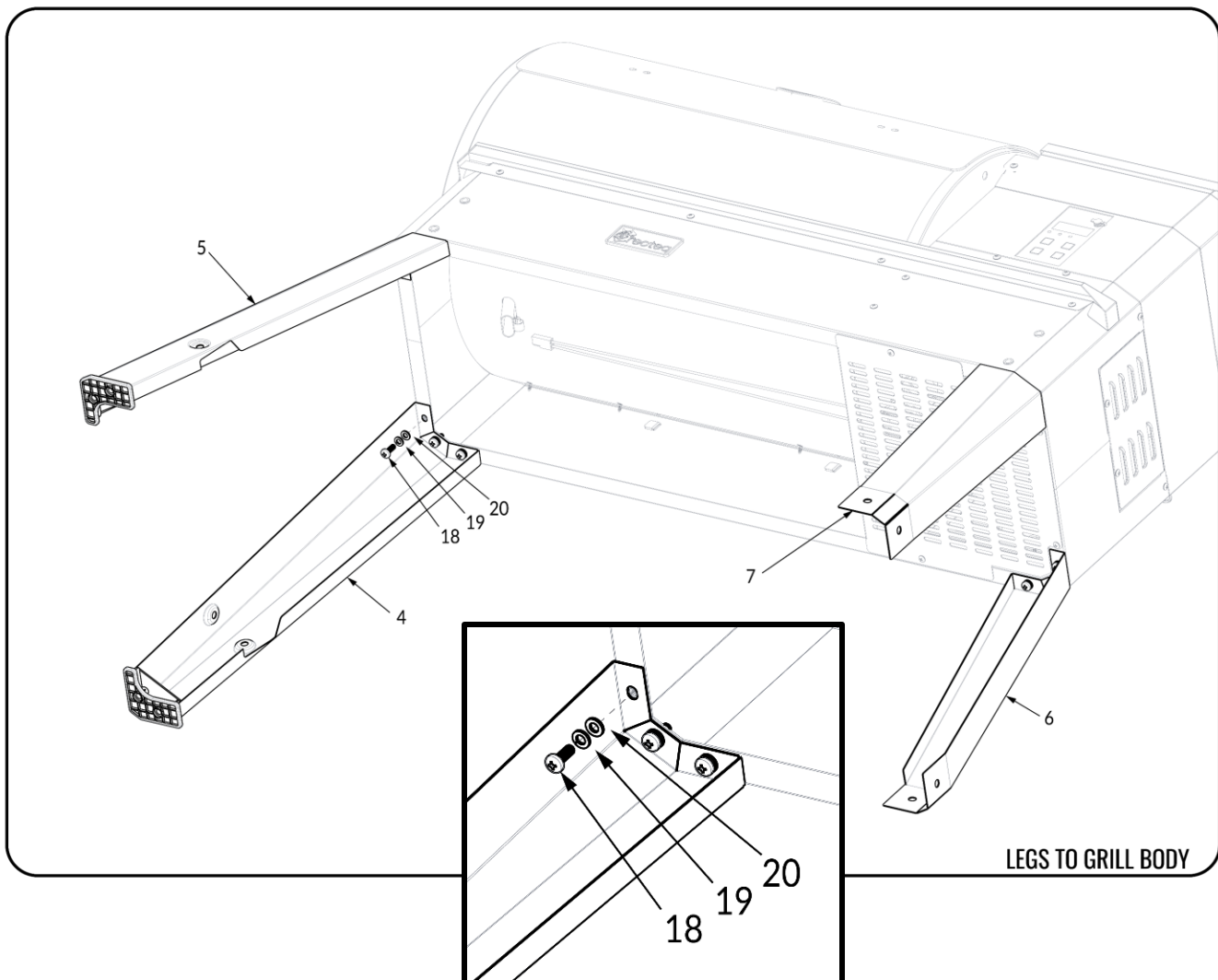

Step 3: Attach Bottom Shelf

Ensure recteq logo is facing front of grill and align shelf with foot of each leg.

Attach all four legs to bottom shelf (item #9) using small bolt, lock washer, and flat washer (items #18, #19, and #20).

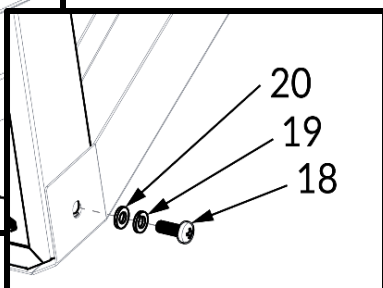
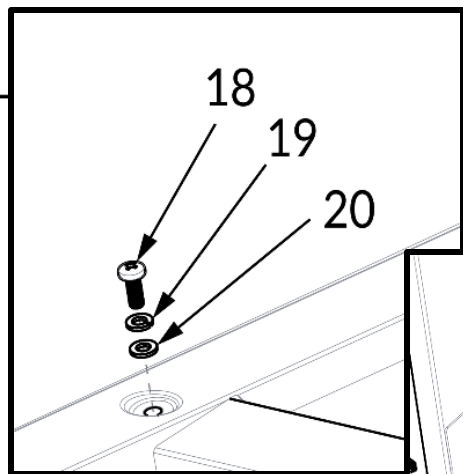
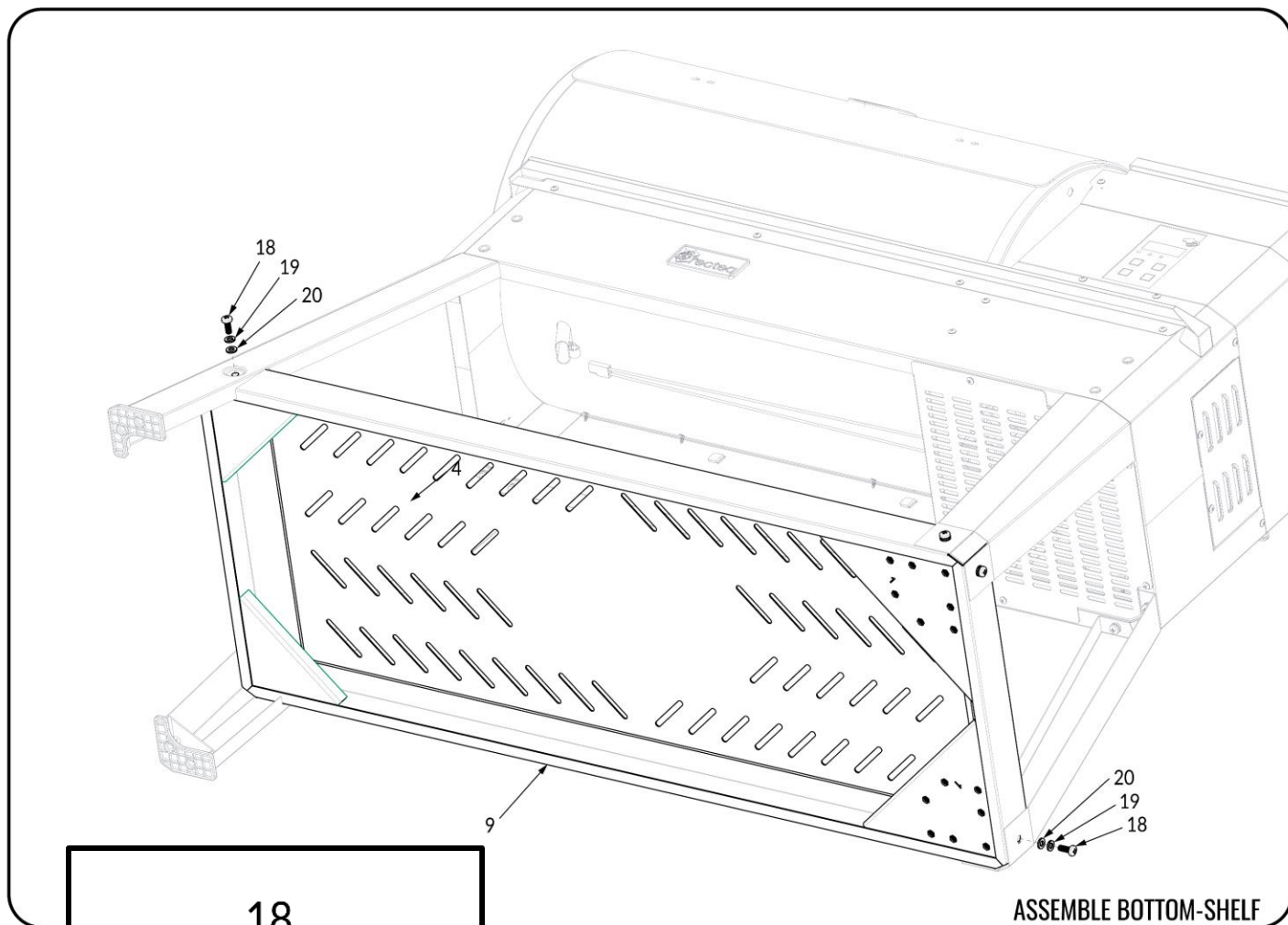

Step 4: Attach Wheels

Attach both fixed wheels (item #17) to the right side of the bottom shelf using medium bolt, lock washer, and flat washer (items #21, #22, and #23).

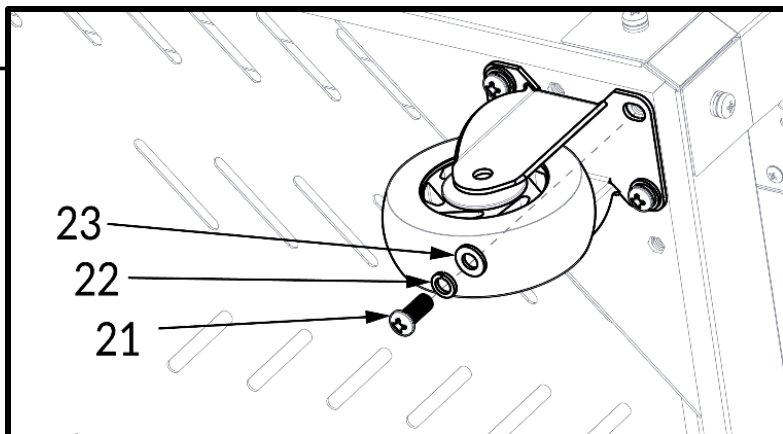
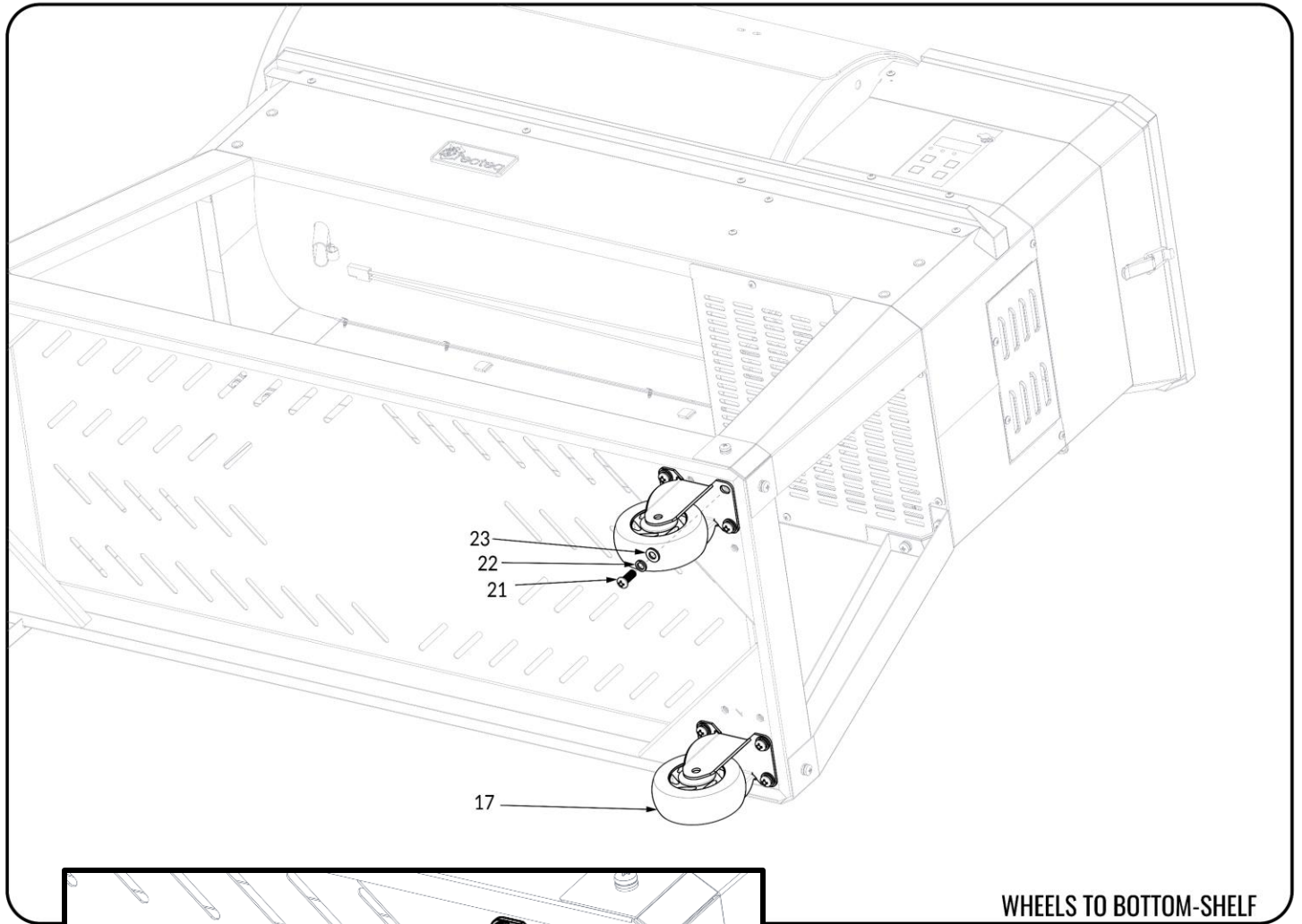

WHEELS TO BOTTOM-SHELF

Step 5: Stand Grill Upright

With assistance (two-person lift recommended), stand grill upright.

Step 6: Bull Horn Handles

Remove the bolts, lock washers, and washers from the Bull Horn Handles.

Attach bull horn handles (items #10 and #11), bull horn brackets (item #12), and grease deflector (item #18) by hand-tightening each bolt.

Check for proper alignment and tighten each bolt.

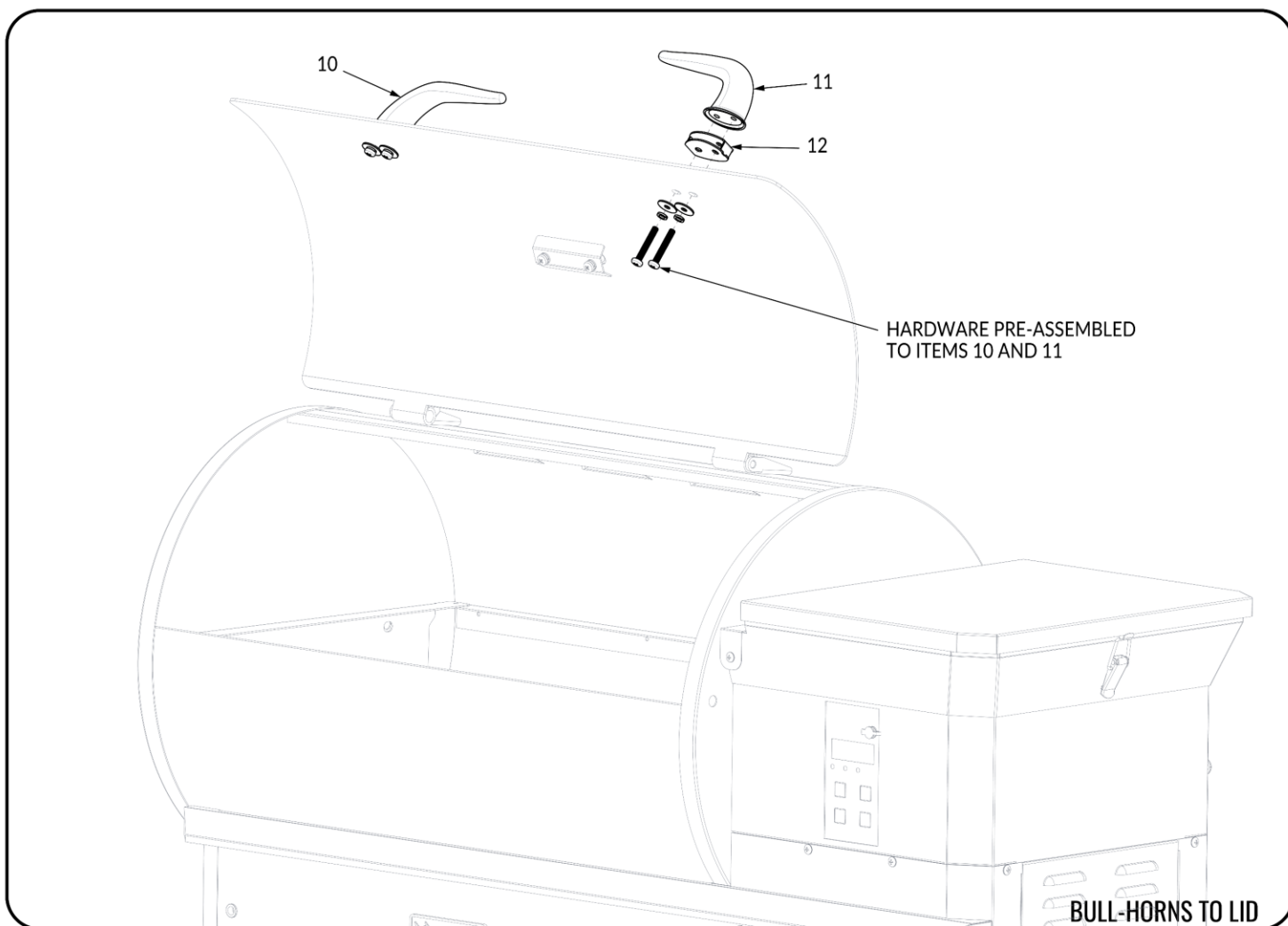

Step 8: Attach Pull Bar to Body

Attach pull bar to body using pre-installed bolts (item #2).

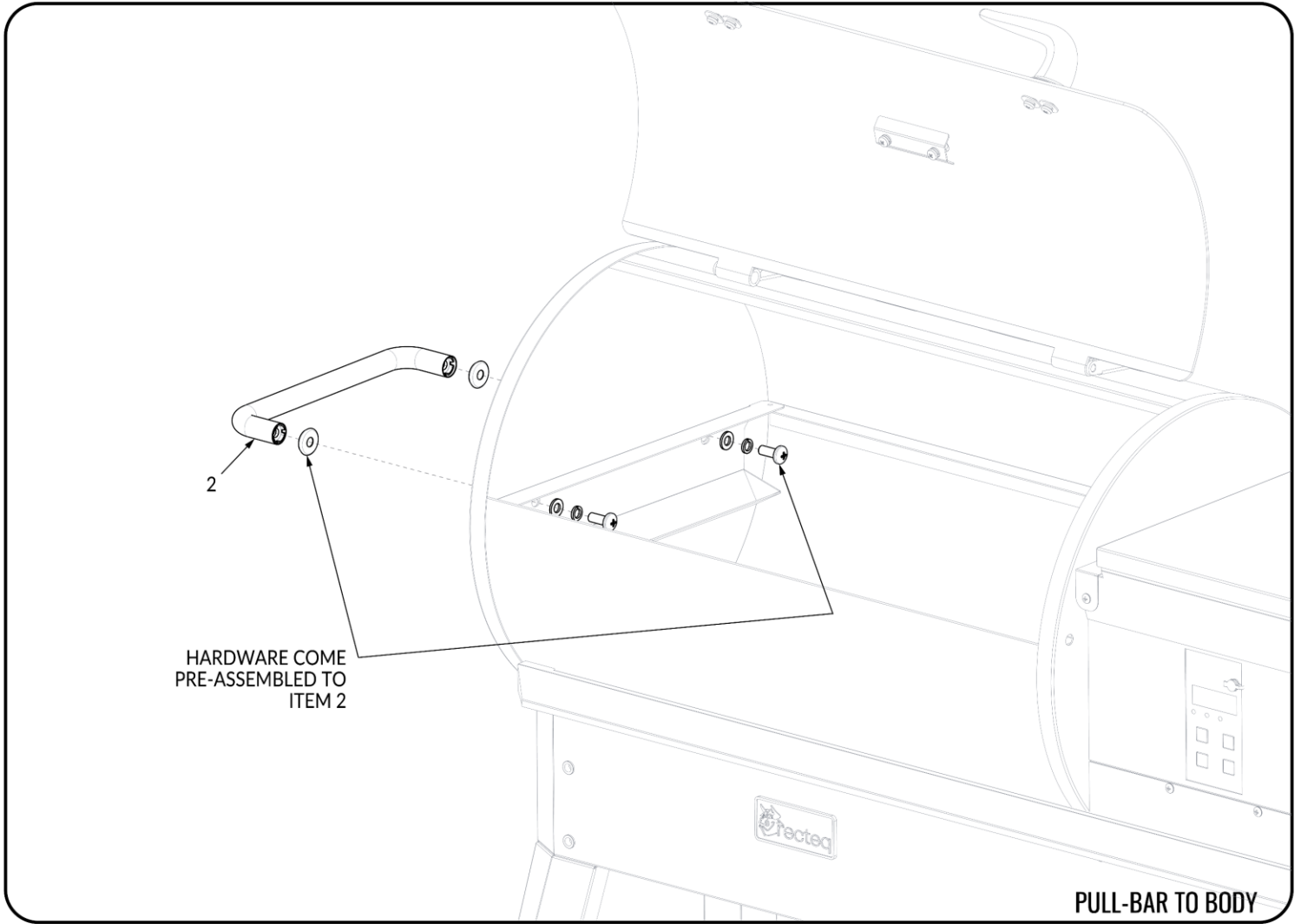

Step 9: Insert Deflector, Drip Pan, Grate, and Bucket

Insert the deflector in the grill, over the fire pot (item #13).

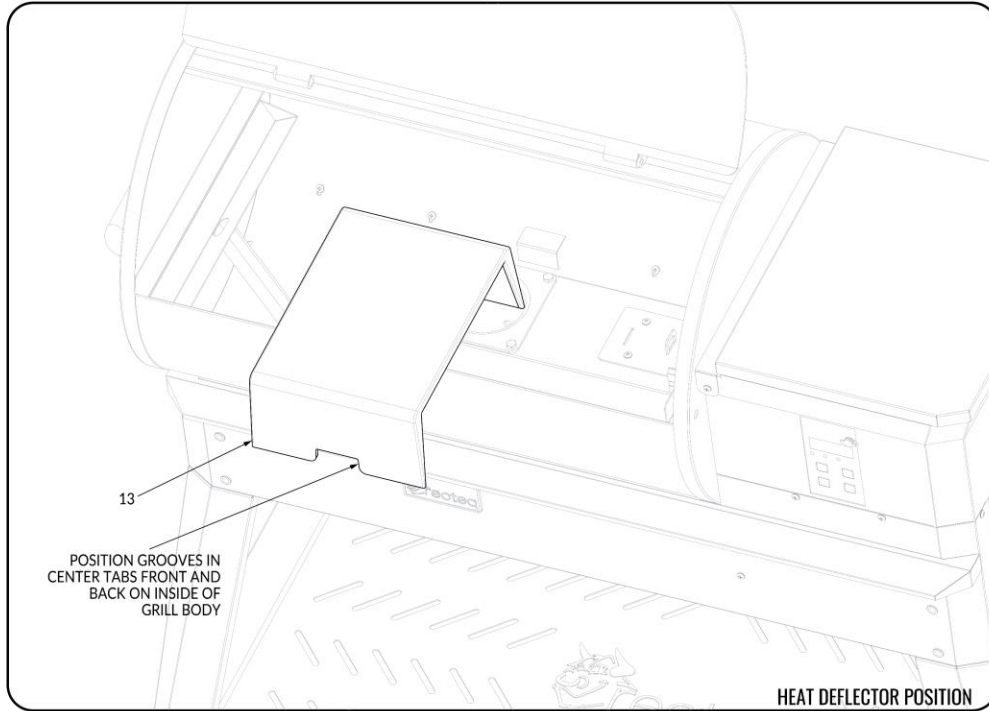

Insert the drip pan with the long edge on the left. Ensure the drip pan is sloped down from right to left (item #8).

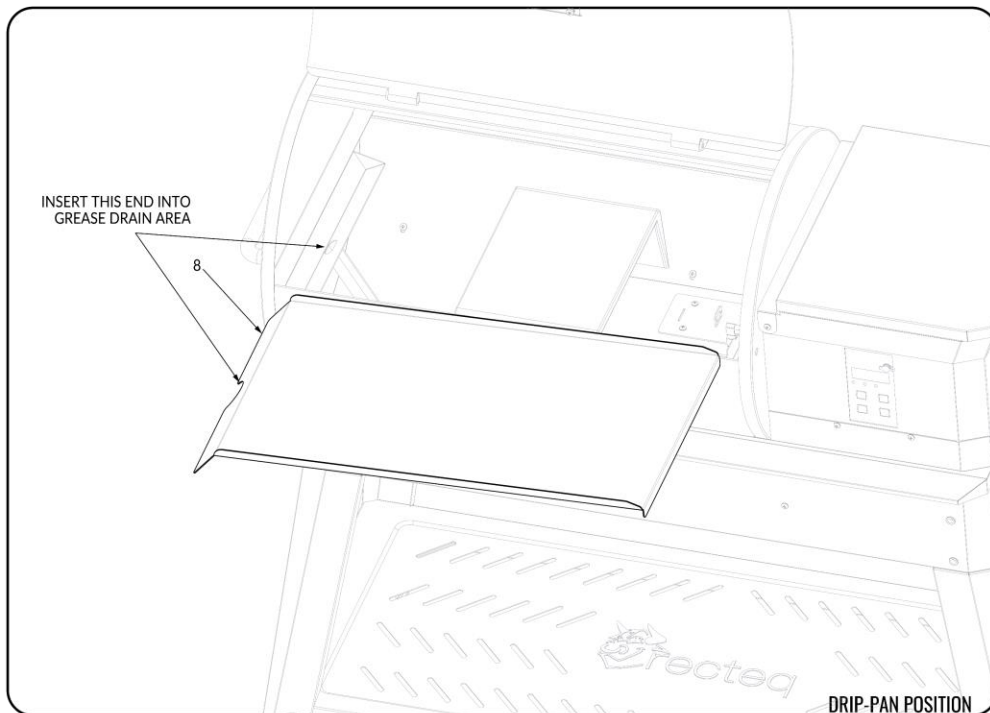

Step 9: Insert Deflector, Drip Pan, Grate, and Bucket (continued)

Insert the main cooking grate into the grill body (item #3).

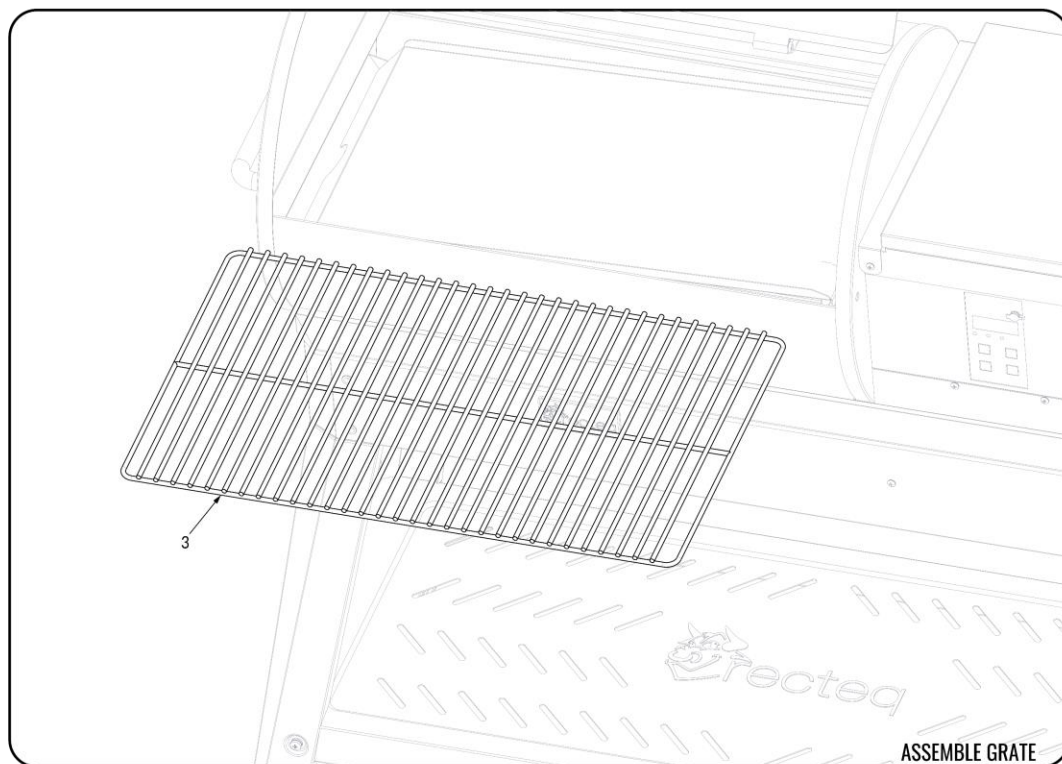

Attach the drip bucket to the grease chute underneath the grill (item #16).

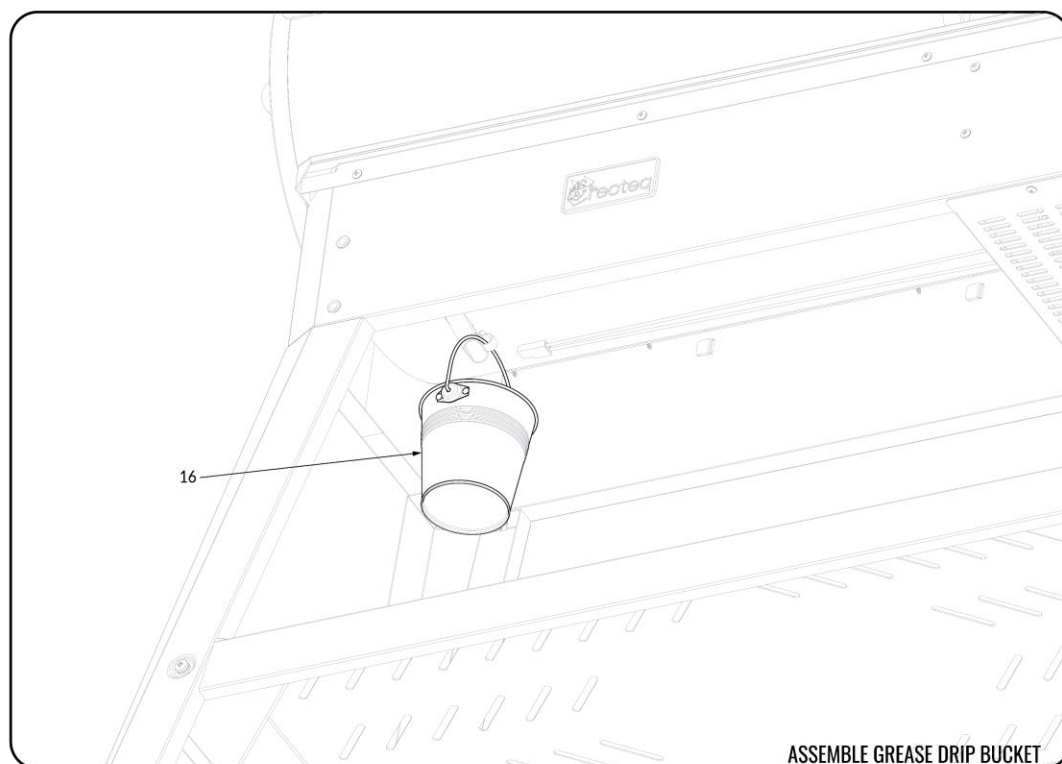

INITIAL SETUP PROCEDURE

Before cooking for the first time, we recommend you remove the cooking grate and wash it with mild soap and water. Fill your hopper at least halfway and place a 1/4 cup of pellets in the firepot. Reinstall the deflector, drip pan (if applicable), and grates and set grill to 400 ° F. Once the grill reaches 400 ° F, let it run with the lid down for 1 hour. This will provide a final cure and remove any residue that may have accumulated during manufacturing and shipping. After this initial burn, your grill is ready for cooking.

OPERATING YOUR GRILL

DO NOT MANUALLY FILL YOUR FIREPOT WITH PELLETS.

DO NOT OVERFIRE OR ATTEMPT TO ACCELERATE THE NATURAL LIGHTING SEQUENCE OF YOUR GRILL.

Press power button to turn grill on and adjust temperature knob to desired temperature.

- Turning the grill ON illuminates the digital readout and activates the startup sequence that powers the ignitor, blower fan, and auger. (auger turns intermittently, by design)
- If your grill fails to light itself within 30 minutes of startup, the Smart Grill Technology™ processor will turn the grill off and display ER-2 on the screen.
- Pressing the power button again activates the shut-down mode of your grill. If grill's actual temperature is below 160 ° F, pressing the power button will simply turn the grill off.
- When the power button is used to shut down your grill, the Smart Grill Technology™ processor will stop adding pellets to the fire pot and the fan will continue running to completely burn the pellets remaining in the fire pot. During this cooling process, the display screen will display FAN. Shortly thereafter, the display screen will change to display AUG - this will push out any embers left in the auger tube.
- When meat probes not in use, protect your meat probe ports by utilizing the rubber probe port protectors.

Temperature Control Buttons: Press Up/Down Arrows to select computer-maintained temperature in 25 ° increments. (Range: 225 ° F - 500 ° F)

Additional Temperature settings: LO and RIOT

LO: LO will display as set temperature when temp is decreased below 225 ° F and Xtreme Smoke will be activated. The grill will feed pellets to the fire at the minimum feed rate (lowest rate possible to maintain a reliable fire). This will produce the most smoke and achieve the lowest temperature possible, given environmental conditions/type of pellets used.

RIOT: RIOT will display as set temperature when temp is increased beyond 500 ° F. Grill will feed pellets to the fire at 100% of auger capacity. This will produce the highest temperature possible, given environmental conditions/type of pellets used.

TEST MODE

Press and hold the Temp Display button and the Down Arrow at the same time. 8888 will appear on the screen. Once it does, let go.

Click Temp Display and the firmware version will appear, press Temp Display again to get to 5-1. Now press the Power Button to move to 5-2. Next, press the Down Arrow for 5-3.

Then the Up Arrow for 5-4.

And finally, Temp Display; now you should see IGN.

Using Temp Display scroll through IGN – AUG – FAN – RTD Test – MEAT PROBE Test – and finally BYE.

Hitting Temp Display while you're on BYE will take you out of Test Mode.

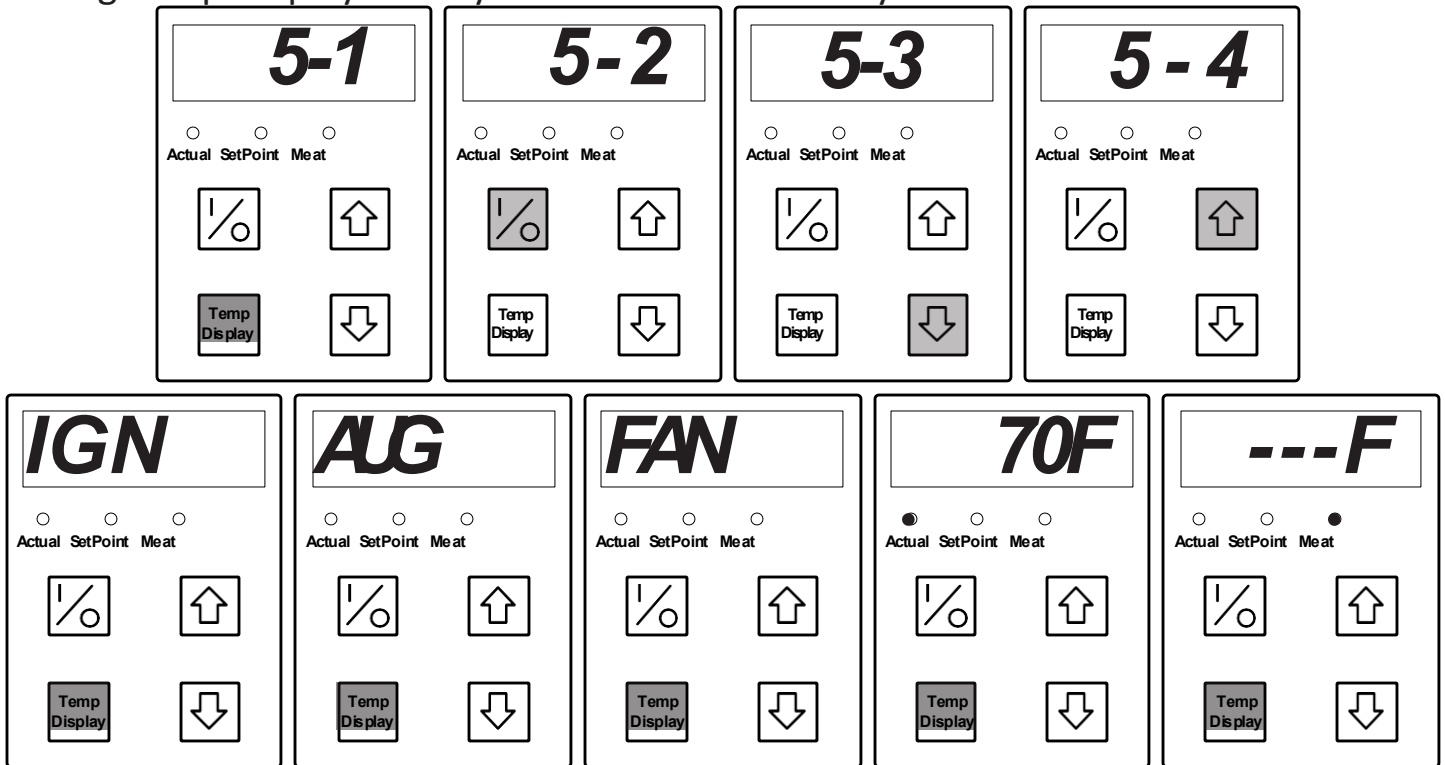

Settings

Press and hold the Up Arrow and Temp Display at the same time until a numeric value appears and the red light is on Set Point, this is the Minimum Feed Rate Setting. (The ranges of the minimum feed rate on the controller is 30 – 250).

Once you press the Temp Display button the red light will move to Actual and the screen should read 0, this is the Offset feature. (Offset ranges are +20 and – 20) Press Temp Display again and the red light will move to Meat, this is the Meat Probe Calibration. (Meat Probe ranges are +10 and – 10)

Use the Up and Down arrows to adjust all the settings – pressing the Temp Display button continuously will cycle between these three screens in a loop. To Exit settings, simply press Power.

SHUTTING OFF GRILL

When you are done cooking, simply press the power button. The blower fan will run continuously and will shut off on its own. Then the auger will feed pellets to conclude the shut-down process. This pushes any smoldering pellets in the auger tube into the firepot where they can safely burn out on their own. Your grill will continue to smoke after cool down is complete. This is normal as the remaining pellets are burning out. It's extremely important to keep the lid closed during this process. Do not move until the grill is fully cooled.

TIPS, TRICKS, AND TEMPS

Preheating

It is important to allow your grill to preheat to achieve your desired cooking temperature before cooking. This allows the entire grill to heat up and quickly return to your desired temperature once your food is introduced. If you do not allow the grill to preheat, you will find that it takes a longer period of time to bring both the grill and the food to your desired cooking temperature. It is important to leave the lid closed during preheating.

Pellet Information

STORE PELLETS IN A DRY SPACE – AWAY FROM FLAMMABLE MATERIALS AND HEATING SOURCES

USE ONLY WOOD PELLET FUEL SPECIFIED FOR COOKING. DO NOT USE PELLET FUEL LABELED AS HAVING ADDITIVES

Premium hardwood pellets contain approximately 8,200 BTUs of heat per pound and leave less than 1% ash residue. Pellets should be stored in a dry area, as wet pellets will swell and turn back into sawdust. For the best results, always use premium hardwood pellets in your grill. The use of grades other than premium hardwood pellets may result in temperature variations, uneven cooking, and poor results. Remember, pellets do not contain preservatives and will deteriorate over time.

Caution: Some wood pellets produced for heating fuel have a high content of softwood which can include pitch and should not be used for cooking. Always check with the pellet manufacturer to ensure that you are cooking with a premium, 100% hardwood pellet.

Smoking	180° F to 275°
Roasting	275° F to 325° F
Braising	325° F to 375° F
Baking	375° F to 450° F
Grilling/Searing	450° F+

TIPS, TRICKS, AND TEMPS

- Always use grill on a level surface and lock/secure wheels.
- Check and clean fire pot regularly; this will ensure proper ignition and heat output.
- Not all pellets are created equal; always use dry and fresh pellets.
- Always store pellets in a dry area.
- Get to know your grill and keep good cooking notes. This will help with consistency.
- Practice makes perfect.
- Always allow your meat to rest before serving.
- Always keep your cooking area clean.
- Avoid lifting the lid more than necessary.
- Wind can cool your grill temperature.
- Always preheat grill to desired temperature before use.
- Wipe off stainless steel surfaces before preheating; dirt and food stains can cook into surface.
- Always check pellet hopper for debris and remove excess pellet dust as needed.
- Leave at least one inch of clearance between food for even cooks (crowded foods will take longer to cook).
- Foods cooked in pans or containers will require more time than foods cooked directly on grate.
- Use your platinum-tipped meat probe to determine meat-doneness; never rely on time.
- Know your food's internal temperature.
- Use long handled tongs and spatulas for turning meats; do not use plastic utensils.
- Do not use accessories not specified for use with this appliance.
- Injecting, mopping, and spritzing are great ways to keep meat from drying out.
- When going low and slow, plan for your meats to stall; larger pieces of meat tend to take longer from 160° F-180° F. Be patient.
- Never unplug your grill to turn it off.
- When not in use, unplug and cover with recteq Premium Grill Cover.
- Use only compatible meat probes with your recteq controller.

Temperatures

Remember, you can't tell whether meat is safely cooked by looking at it. Any cooked, uncured red meats (including pork) can be pink, even when the meat has reached a safe internal temperature.

After you remove the meat from your grill, allow it to rest.

- Hot foods should be held at 140° F or warmer.
- Cold foods should be held at 40° F or colder.
- Perishable foods should not be left out for more than 2 hours at room temperature; 1 hour when the temperature is above 90° F.
- Always follow food safety guidelines provided by the USDA.

MAINTENANCE & CLEANING

- CLEAN YOUR FIRE POT EVERY 3-5 COOKS OR AFTER EVERY 16 HOURS OF COOKING TIME, TO ENSURE PROPER AIRFLOW.
- PERIODICALLY CLEAN OUT VENTS/SMOKESTACK TO ENSURE PROPER AIRFLOW AND MAXIMUM PERFORMANCE.
- DISPOSAL OF ASHES - ASHES SHOULD BE PLACED IN A METAL CONTAINER WITH A TIGHT-FITTING LID. THE CLOSED CONTAINER OF ASHES SHOULD BE PLACED ON A NONCOMBUSTIBLE FLOOR OR ON THE GROUND, WELL AWAY FROM ALL COMBUSTIBLE MATERIALS, PENDING FINAL DISPOSAL. IF THE ASHES ARE DISPOSED OF BY BURIAL IN SOIL OR OTHERWISE LOCALLY DISPERSED, THEY SHOULD BE RETAINED IN THE CLOSED CONTAINER UNTIL ALL CINDERS HAVE THOROUGHLY COOLED.
- Use a grill brush to clean your cooking grate after every cook to provide years of trouble-free use.
Note: Make sure that no bristles have shed onto the cooking grate.
- Use a mild soap and water to clean the exterior of your grill. AVOID USING CAUSTIC CLEANERS! ie: ajax, comet, etc.
- If left in an exposed area, keep your grill covered and unplugged when not in use.
- Never let your pellets get wet; they will swell and jam your auger.
- If grill is not used for 6 weeks or more, it is advised to remove all pellets from hopper.
- Remove pots and pans while the operating appliance is unattended, to reduce the risk of fire

Never store the grill in a small space or place in a vehicle unless completely cool and fire is verified as extinguished. Never move the grill while it is still hot. Never move the grill without assistance.

After completing a low and slow cook that has caused the accumulation of grease, you must clean and/or remove all grease accumulating items before cooking again. Failure to do so will most certainly cause a grease fire in your grill.

TROUBLESHOOTING

We pride ourselves on our grills, grilling accessories, and on our commitment to serve you. Please consult the chart below to help resolve issues you may encounter. Also, please don't hesitate to contact us with any issues.

(706) 922-0890

Issue	Potential Cause	Solution
Grill will not light/turn on	Power	Make sure power is plugged into working GFCI outlet, and outlet is not tripped. Unplug grill and check for blown fuse; refer to controller schematic on page 23.
	Fuse	Replace fuse manually and try again. Call Customer Service or visit recteq.com if problem persists.
	Igniter	Remove cooking grate, heat deflector, and drip pan; visually inspect fire pot and if after 10 minutes: <ul style="list-style-type: none"> •your pellets are feeding •your blower fan is running •your grill is still not lighting Then your igniter rod may need to be replaced. Call Customer Service. (706)922-0890
	Auger Motor	Remove cooking grate, heat deflector, and drip pan (if applicable); visually inspect auger turning in the fire pot. (Note: the auger turns very slowly) If auger is not turning, you may have an obstruction in your hopper. Clean out pellets and try again. If problem persists, your auger motor may need to be replaced. Call Customer Service. (706)922-0890
	Control Board	UNPLUG GRILL. Check to make sure the fuse is intact and has not blown. Check for any loose wire connections. If any wires have become detached, refer to controller schematic.

Issue	Potential Cause	Solution
Grill is smoking excessively/ smoke is discolored	Pellet quality/age	Inspect pellets; ensure that pellets are dry and have not broken down into sawdust. If problem persists, remove pellets from the hopper and clean ash from your firepot, then replace with fresh dry pellets.
	Excess ash in fire pot	Check the burn pot for ash and clean as necessary (it's advised to clean fire pot every 3-5 uses).
	Blower fan	Unplug grill. Remove access panel; visually inspect blower fan for any obstructions, loose connections, bugs, etc. Remove obstructions. Power grill on. If problem persists, unplug grill. Spin fan manually for several revolutions. Plug grill back in. If problem persists, your blower fan may need to be replaced. Call customer service. (706)922-0890
Grill will not heat up to or maintain proper temp	Pellet quality/age	Inspect pellets; ensure that pellets are dry and have not broken down into sawdust. If problem persists, remove pellets from the hopper and clean ash from your firepot, then replace with clean dry pellets.
	Insufficient airflow	Check firepot/smokestack/vents for any obstructions/ ash accumulation.
	Excess ash in fire pot	Check fire pot for ash and clear as necessary.
Fire continues to go out	Pellet quality/age	Inspect pellets; ensure that pellets are dry and have not broken down into sawdust. If problem persists, remove pellets from the hopper and clean ash from your firepot, then replace with clean dry pellets.
	Hopper obstruction	Unplug grill. Remove pellets from hopper. Clean hopper of any obstructions or build up.
	Pellet Bridge	Excessively long pellets and/or excess dust can cause pellets not to fall into the auger.

Issue	Potential Cause	Solution(s)
Pellets are not being delivered to fire pot	Hopper obstruction	Unplug grill. Remove pellets from hopper. Clean hopper of any obstructions or build up.
	Auger Failure/Jam	Remove cooking grate and heat deflector plate; visually inspect auger turning in the fire pot. (Note: the auger turns very slowly) If auger is not turning, you may have an obstruction in your hopper. Clean out pellets and try again. If problem persists, your auger motor may need to be replaced. Call Customer Service. (706)922-0890
Flare ups	Excessively greasy food while temperature setting is too high	Cook at 350°F or below when cooking excessively fatty foods.
Excessive grease/build up	Excessively greasy food	Cook at 350°F or below when cooking excessively fatty foods.
Smoke coming from hopper	Excess ash in firepot	Clean grill interior.
	Pellet level very low in hopper or excess dust in hopper/auger	Add more pellets to hopper or remove pellets and vacuum excess dust from hopper
	Grease buildup in vents/smokestack	Remove pellets from hopper and vacuum out hopper, auger tube, and fire pot.
ER-1	Power Failure	Make sure power is plugged into working GFCI outlet, and outlet is not tripped. Turn grill off, then back on again to reset controller and clear code.
ER-2	Grill hasn't ignited in over 30 minutes	Refer to "Grill will not light/turn on" in Troubleshooting.
ER-3	RTD unplugged/grill over heated	Check connection and let grill cool. Turn grill off, then back on again to reset controller and clear code.

TROUBLESHOOTING

In case of igniter failure, you can start your recteq manually:

1. Remove the stainless-steel grates, drip pan (if applicable), and heat deflector.
2. Clean out fire pot and place no more than 1/2 cup of pellets in the bottom. Add a small amount of solid fuel fire starter, such as those made from sawdust and wax, or use wood shavings.

Tip: A paper towel, shredded cardboard, or shredded newspaper can work as a substitute.

If you have a torch lighter, a fire starter is not needed.

3. Light the fire starter.
4. After the pellets are burning briskly, turn on your grill. If your fire goes out, repeat steps 1-4.
5. If your fire stays lit, replace the stainless heat deflector, drip pan, and cooking grates then close the lid.

Be careful not to touch the fire.

CAUTION: Do not use flammable liquids such as gasoline, gasoline-type lantern fuel, kerosene, charcoal lighter fluid, or similar liquids to start or freshen-up the fire! Keep all such liquids well away from the grill while it is in use.

IF YOU NEED ASSISTANCE, PLEASE CONTACT OUR U.S. BASED CUSTOMER SUPPORT CENTER (706)922-0890

WARRANTY

This limited warranty covers the Porch Pro Wood Pellet Grill manufactured by “recteq, LLC” Porch Pro carries a 4-year limited warranty from the date of purchase by the original owner against defects in material and workmanship when subjected to normal residential use. Limited warranty does not apply to paint, grill cover, or damage caused from corrosion.

Conditions of Limited Warranty

1. During the term of the limited warranty, recteq, LLC’s obligation shall be limited to replacement of covered, failed components. recteq will repair or replace parts returned to recteq, freight prepaid, if the part(s) are found by recteq to be defective upon examination. recteq shall not be liable for transportation charges, labor costs, or export duties.
2. recteq takes every precaution to utilize materials that retard rust including the use of high temperature paint and stainless steel where advisable. Even with these safeguards, the protective coatings can be compromised by various substances and conditions beyond recteq’s control. High temperatures, excessive humidity, chlorine, industrial fumes, fertilizers, lawn pesticides, and salt are some of the substances that can affect paint and metal coatings. For these reasons, the limited warranties DOES NOT COVER RUST OR OXIDATION FOR ANY REASON.
3. The warranty is based on residential use. Warranty coverage does not apply to products used in commercial applications.

Exceptions to the Limited Warranty

There is no written or implied performance warranty on recteq, as the manufacturer has no control over the installation, operations, cleaning, maintenance, or the type of fuel burned. This limited warranty will not apply nor will recteq assume responsibility if your product has not been installed, operated, cleaned, and maintained in strict accordance with the manufacturer’s instructions. The warranty does not cover damage or breakage due to misuse, improper handling, or modifications. NEITHER THE MANUFACTURER, NOR THE SUPPLIERS TO THE PURCHASER ACCEPTS RESPONSIBILITY, LEGAL OR OTHERWISE, FOR THE INCIDENTAL OR CONSEQUENTIAL DAMAGE TO THE PROPERTY OR PERSONS RESULTING FROM THE USE OF THIS PRODUCT. ANY WARRANTY IMPLIED BY LAW, INCLUDING BUT NOT LIMITED TO IMPLIED WARRANTIES OF MERCHANTABILITY OR FITNESS, SHALL BE LIMITED TO FOUR (4) YEARS FROM THE DATE OF ORIGINAL PURCHASE. WHETHER A CLAIM IS MADE AGAINST THE MANUFACTURER BASED ON THE BREACH OF THIS WARRANTY OR ANY OTHER TYPE OF WARRANTY EXPRESSED OR IMPLIED BY LAW, MANUFACTURER SHALL IN NO EVENT BE LIABLE FOR ANY SPECIAL, INDIRECT, CONSEQUENTIAL, OR OTHER DAMAGES OF ANY NATURE WHATSOEVER IN EXCESS OF THE ORIGINAL PURCHASE PRICE OF THIS PRODUCT. ALL WARRANTIES BY MANUFACTURER ARE SET FORTH HEREIN AND NO CLAIM SHALL BE MADE AGAINST MANUFACTURER ON ANY ORAL WARRANTY OR REPRESENTATION. Some states do not allow the exclusion or limitation of incidental or consequential damages, or limitations of implied warranties, so the limitations or exclusions set forth in this limited warranty may not apply to you. This limited warranty gives you specific legal rights and you may have other rights, which vary from state to state.

The limited warranty for FOUR (4) years is in lieu of all other warranties expressed or implied, by law or otherwise, and recteq does not authorize any person or representative to assume for recteq any obligation or liability in connection with the sale of this product. This means that no warranties, either expressed or implied, are extended to persons who purchase the product from anyone other than recteq or an authorized recteq Distributor.

Procedure for Warranty Registration and Service

Provide the following information to recteq by phone: (706)922-0890 or email: support@recteq.com

- Purchaser’s name, address, shipping address, email address, phone #, grill model, grill serial number, date of purchase, and place of purchase

If service is required, please provide an accurate description of the issue