



1155 Perimeter Center West Suite 650  
Sandy Springs, GA 30338

RT-480SS  
SMOKESTONE



## Assembly Manual

**READ ALL INSTRUCTIONS BEFORE INSTALLING AND USING THIS APPLIANCE**

Please read this entire manual before installation and use of this pellet fuel-burning appliance. Failure to follow these instructions could result in property damage, bodily injury, or even death. Contact local building or fire officials about restrictions and installation inspection requirements in your area. Save these instructions.

**A MAJOR CAUSE OF FIRES IS FAILURE TO MAINTAIN REQUIRED CLEARANCES (AIR SPACES) TO COMBUSTIBLE MATERIALS. IT IS OF UTMOST IMPORTANCE THAT THIS PRODUCT BE INSTALLED IN ACCORDANCE WITH THESE INSTRUCTIONS.**



# WARNING & SAFETY INFORMATION



**READ ALL WARNING AND SAFETY INFORMATION BEFORE OPERATING GRIDDLE  
FOR OUTDOOR USE ONLY**

NEVER ATTEMPT TO EMPTY, CLEAR, DISPOSE, OR REMOVE ASHES WHILE GRIDDLE IS HOT. IF YOUR GRIDDLE IS EQUIPPED WITH AN ASH CLEARING LEVER, DO NOT MOVE LEVER UNTIL GRIDDLE IS COMPLETELY COOL

DO NOT STORE OR USE COMBUSTIBLE MATERIALS IN OR NEAR THIS APPLIANCE

NEVER TOUCH OR ATTEMPT TO MOVE GRIDDLE WHILE HOT OR WITHOUT ASSISTANCE

NEVER MOVE YOUR GRIDDLE WHILE IN OPERATION AND ALWAYS LOCK/SECURE WHEELS

YOUR RECTEQ GETS VERY HOT. USE HEAT RESISTANT GLOVES FOR OPENING/CLOSING LID, ESPECIALLY AT TEMPERATURES ABOVE 400°

KEEP CHILDREN AND PETS AWAY WHILE GRIDDLE IS HOT. USE EXTREME CAUTION WHEN COOKING AT ALL TEMPERATURES

TO PREVENT FLARE UPS, CLEAN/REMOVE RESIDUAL GREASE FROM DRIP PANS, GRATES, AND BOTTOM OF GRIDDLE REGULARLY, ESPECIALLY PRIOR TO COOKING ABOVE 350°

IF NECESSARY, USE 14 GAUGE OR HEAVIER EXTENSION CORD THAT'S RATED FOR OUTDOOR USE

ALWAYS UNPLUG WHILE NOT IN USE

NEVER STORE ANY GRIDDLE IN A SMALL SPACE OR PLACE IN A VEHICLE UNLESS COMPLETELY COOL AND FIRE IS VERIFIED AS EXTINGUISHED

LEAVE A MINIMUM OF 18" CLEARANCE FROM THE UNIT TO COMBUSTIBLE CONSTRUCTION AND/OR MATERIALS AT THE REAR, SIDES, AND TOP

USE ON LEVEL GROUND AND NEVER USE UNDER COMBUSTIBLE CEILINGS OR OVERHANGS

NEVER USE ON A COMBUSTIBLE FLOOR. USE ON A NONCOMBUSTIBLE FLOOR OR FLOOR PROTECTED WITH NONCOMBUSTIBLE SURFACE WHERE PROTECTIVE SURFACE HAS BEEN APPROVED FOR SUCH USE BY THE AUTHORITY HAVING JURISDICTION



# WARNING & SAFETY INFORMATION



**READ ALL WARNINGS AND SAFETY INFORMATION BEFORE OPERATING GRIDDLE**

NEVER PLUG IN YOUR GRIDDLE WITHOUT ALL SERVICE ACCESS GRATES/PANELS  
INSTALLED AND ALWAYS PLUG INTO PROPERLY GROUNDED OUTLET (GFCI)

OCCASIONALLY, YOUR FIRE POT, VENTS/SMOKESTACKS SHOULD BE INSPECTED FOR  
OBSTRUCTIONS TO MAKE SURE PROPER AIRFLOW AND PROPER VENTILATION IS  
MAINTAINED

USE HEAT-RESISTANT MITTS OR GLOVES WHEN HANDLING FOOD, PANS, GRATES, ETC.  
WHILE OPERATING THIS UNIT. LONG HANDLED, NON-PLASTIC UTENSILS ARE ALSO  
RECOMMENDED

BE AWARE OF AND/OR REMOVE LOOSE CLOTHING, JEWELRY, AND ACCESSORIES BEFORE  
USING GRIDDLE

BEFORE COVERING YOUR GRIDDLE, MAKE SURE THAT THE GRIDDLE HAS COOLED  
COMPLETELY

NEVER PUT YOUR HAND IN THE PELLET HOPPER OR ATTEMPT TO SERVICE ANY PART OF  
YOUR GRIDDLE WHILE YOUR GRIDDLE IS PLUGGED IN. KEEP ALL PROTECTIVE GUARDS IN PLACE

**CARBON MONOXIDE WARNING:**

FOLLOW THESE GUIDELINES TO PREVENT THIS COLORLESS, ODORLESS GAS FROM POISONING YOU,  
YOUR FAMILY, OR OTHERS.

KNOW THE SYMPTOMS OF CARBON MONOXIDE POISONING: HEADACHE, DIZZINESS, WEAKNESS,  
NAUSEA, VOMITING, SLEEPINESS, AND CONFUSION. CARBON MONOXIDE REDUCES THE BLOOD'S  
ABILITY TO CARRY OXYGEN. LOW BLOOD OXYGEN LEVELS CAN RESULT IN LOSS OF CONSCIOUSNESS  
AND DEATH.

SEE A DOCTOR IF YOU OR OTHERS DEVELOP COLD OR FLU-LIKE SYMPTOMS WHILE COOKING OR IN  
THE VICINITY OF THIS APPLIANCE. CARBON MONOXIDE POISONING, WHICH CAN EASILY BE MISTAKEN  
FOR A COLD OR FLU, IS OFTEN DETECTED TOO LATE.

ALCOHOL CONSUMPTION AND DRUG USE INCREASES THE EFFECTS OF CARBON MONOXIDE  
POISONING.

CARBON MONOXIDE IS ESPECIALLY TOXIC TO MOTHER AND CHILD DURING PREGNANCY, INFANTS,  
THE ELDERLY, SMOKERS, AND PEOPLE WITH BLOOD OR CIRCULATORY SYSTEM PROBLEMS, SUCH AS  
ANEMIA OR HEART DISEASE.

# Welcome to the recteq family!

Congratulations on the purchase of your new recteq wood fired pellet griddle. With proper care and maintenance, your recteq will provide you years of trouble-free operation. Please review the following information carefully for useful tips and information that will help you utilize your griddle's extensive features and benefits.

To see our favorite recipes and cooking tips, visit [recteq.com](http://recteq.com). As you become familiar with your recteq, you will find that indoor cooking becomes the exception and not the rule in your house. With the ability to easily cook foods that meet or often exceed restaurant quality, you will no longer want to dine out and pay for food that does not live up to the recteq standard. Also, don't be alarmed when your neighbors call and ask if you will 'recteq' some meat for them...This is a common occurrence among recteq owners.

We invite you to join the vibrant and growing recteq social media community. Whether you want to contribute your own tips and recipes, learn from others, or a bit of both, please jump right in. You now have an incredible tool for cooking. Let's see how you use it!

Thank you for choosing recteq.

Ray Carnes & Ron Cundy Co-Founders, recteq, LLC

A handwritten signature in black ink that reads "Ray Carnes". The signature is fluid and cursive, with the first letters of "Ray" and "Carnes" being significantly larger and more stylized than the rest of the letters.A handwritten signature in black ink that reads "Ron Cundy". The signature is fluid and cursive, with the first letters of "Ron" and "Cundy" being significantly larger and more stylized than the rest of the letters.

# CONTENTS

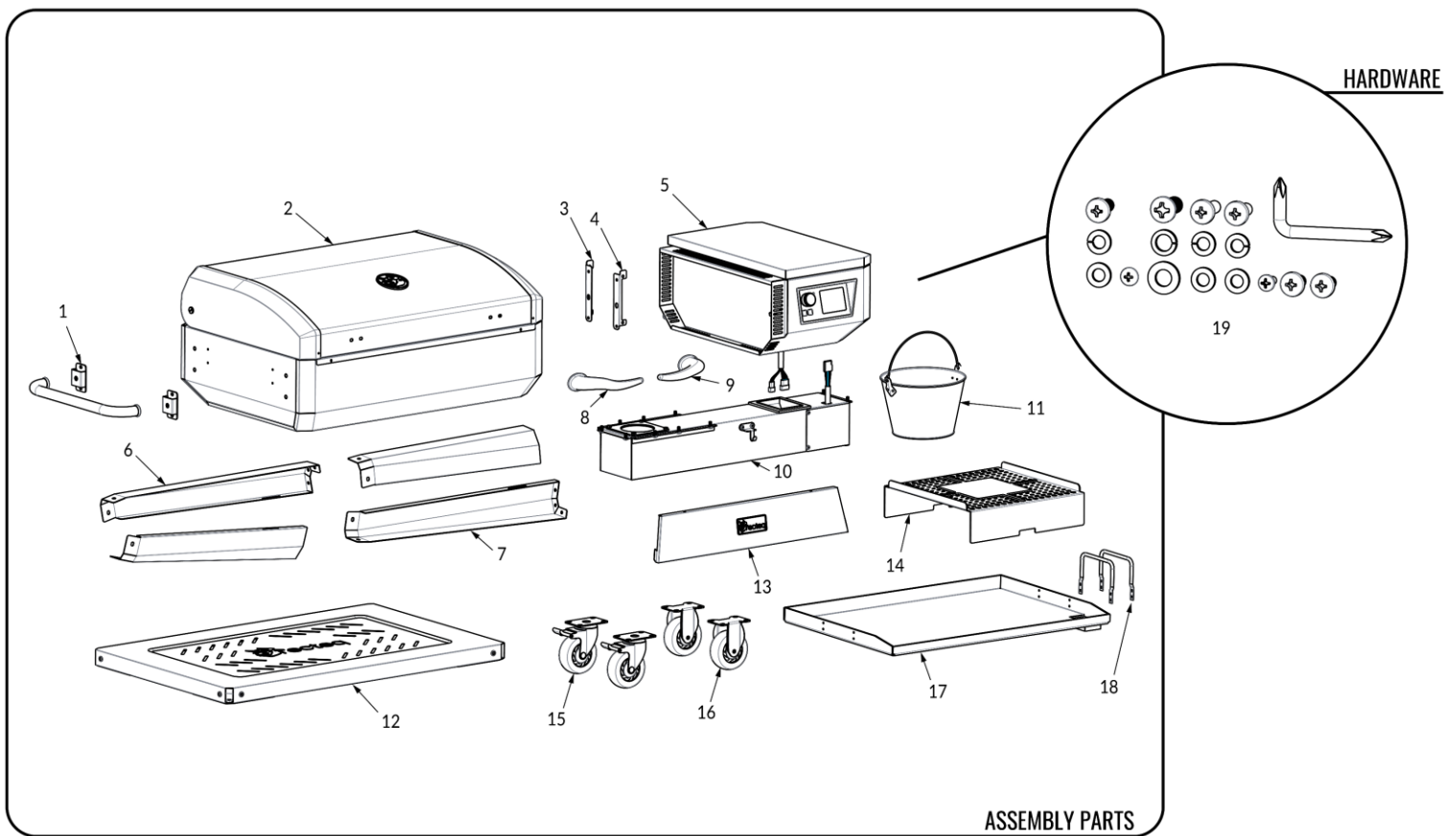

1. Pull-Bar and Brackets
2. Griddle Body and Lid
3. Rear-Side Hopper Bracket
4. Front-Side Hopper Bracket
5. Hopper
6. Front-Right/Back-Left Leg
7. Front-Left/Back Right Leg
8. Left Bull-Horn
9. Right Bull-Horn
10. Airbox
11. Large Drip Bucket
12. Bottom Shelf
13. Front Skirt
14. Heat Deflector
15. Caster Wheels
16. Fixed Wheels
17. Griddle Plate
18. Griddle Handles
19. Hardware Pack (not pictured)
20. Internal Hopper Grate (Not Pictured)

## ASSEMBLY

### Step 1: Unpack and Prepare for Assembly

Remove and unwrap all items from griddle body.

With assistance, lay griddle body on its back using packing material to protect from damage. Be aware of sharp edges and points while assembling.

**Note: All hardware is labelled for assembly use on hardware pack**

### Step 2: Attach Airbox to Body

Starting with griddle body on its back, attach airbox to body using 8 small bolts with lock washer and flat washer for each bolt (see diagram).

Hand-tighten all bolts before tightening with screwdriver or drill.

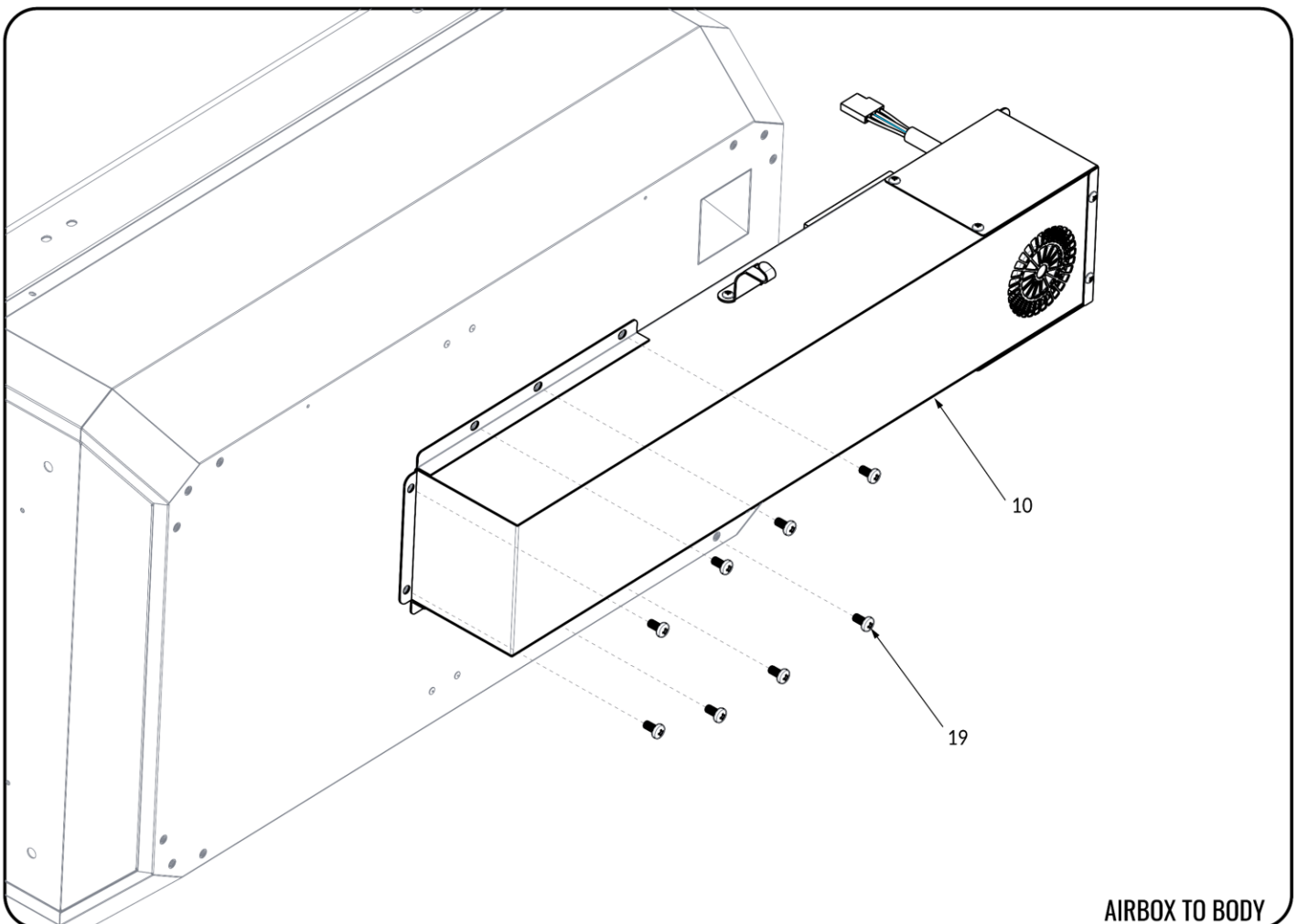

### Step 3: Attach Temp Probe Wire, Hopper Brackets, and Wiring Harness

Slide temperature probe wire from body through hole in hopper bracket.

Attach each hopper bracket to body using bolt, lock washer, and flat washer.

Secure probe wire and wiring harness connections together.

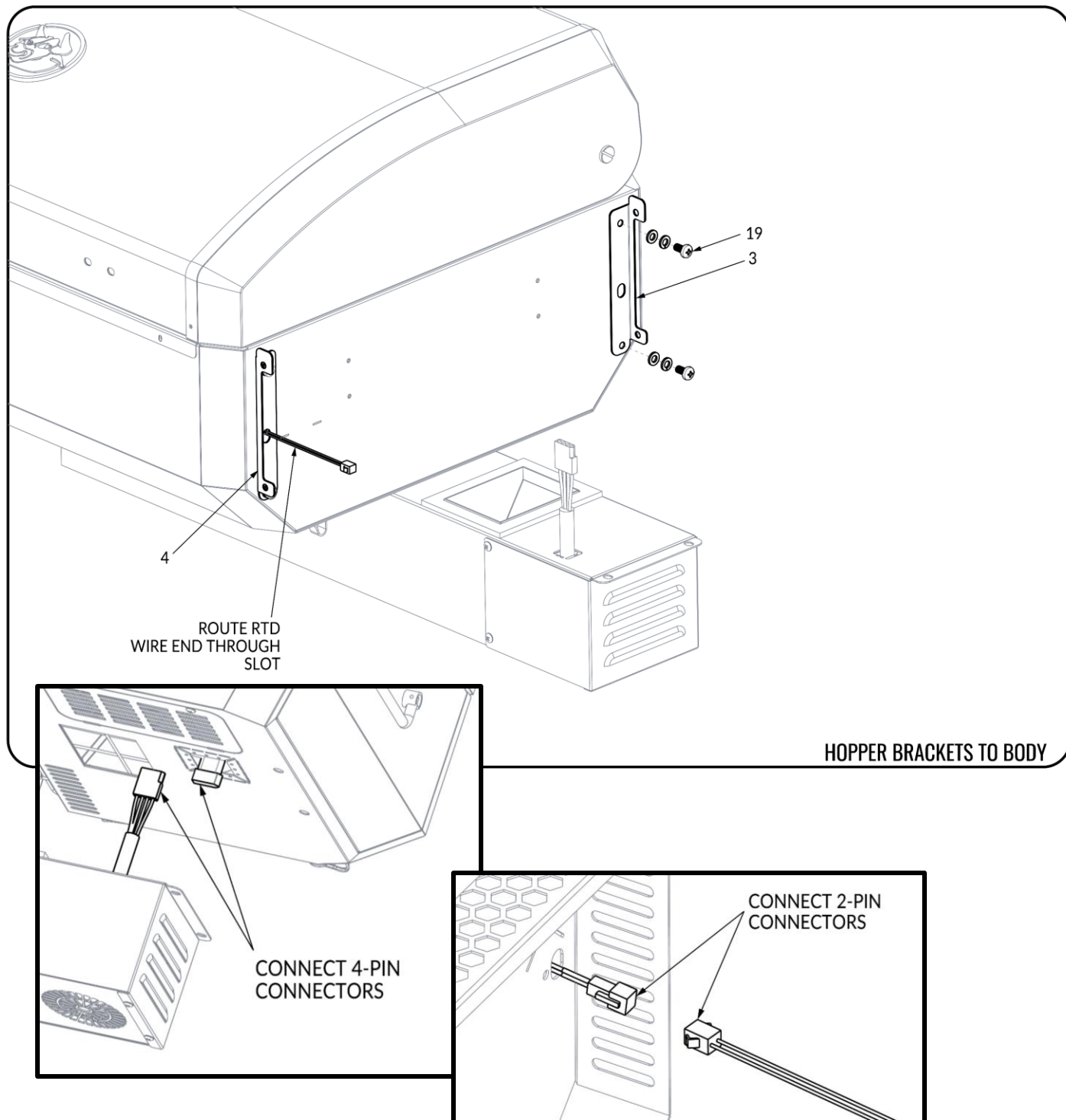

#### Step 4: Attach Hopper to Griddle Body

Slide hopper over hopper brackets and secure with bolt and washer. Two bolts are needed on both front and back; the griddle body will need to be adjusted to allow access to the back. Fasten the last two bolts for the airbox to the underside of the hopper.

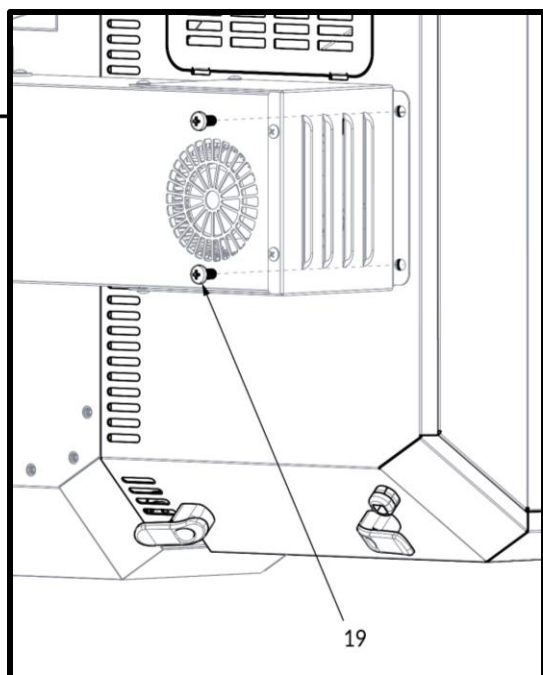
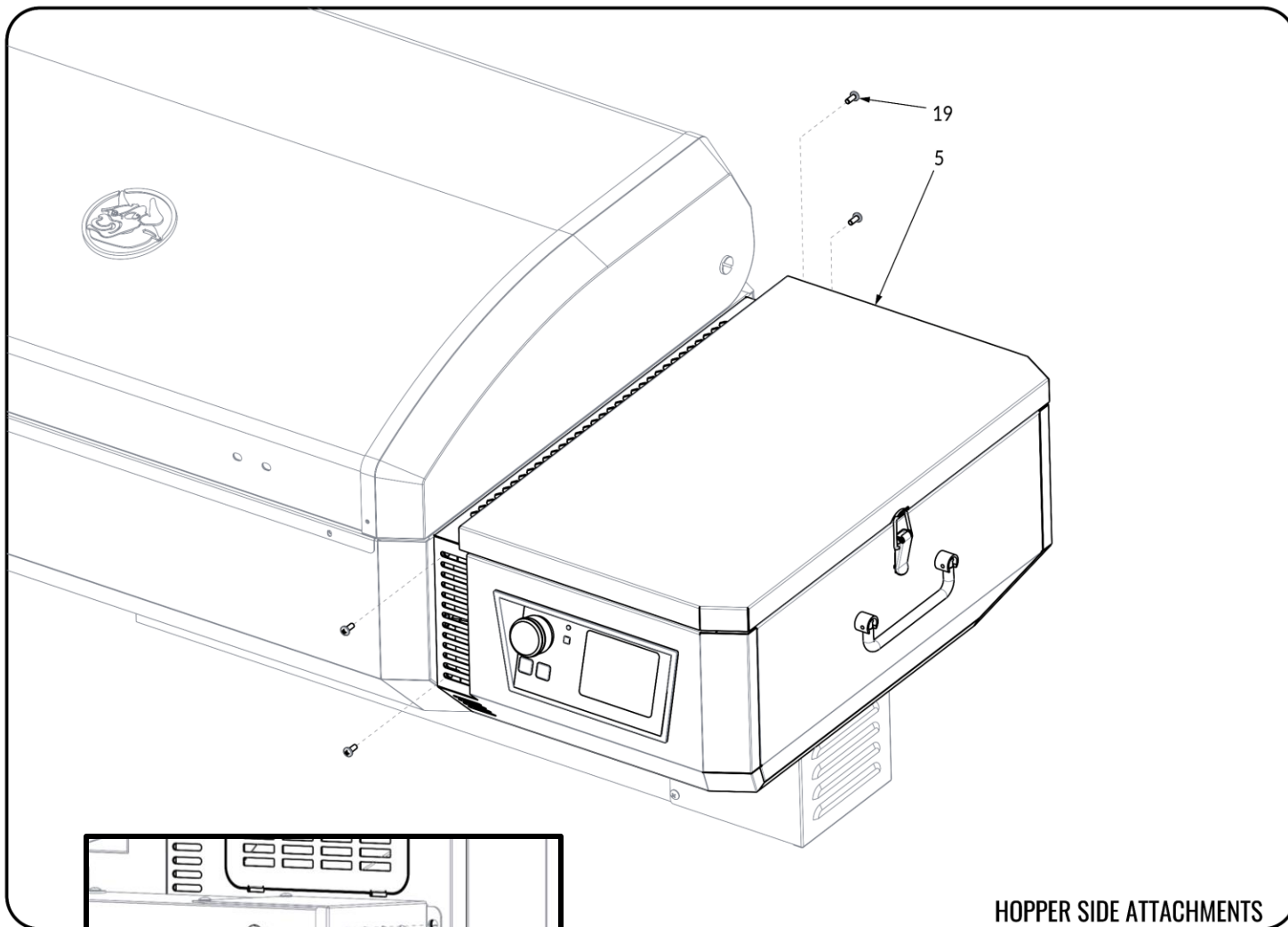

## Step 5: Attach Legs and Logo Plate

Start with griddle on back. Attach each leg to all four corners of the griddle body using 3 small bolts with lock washer and flat washer for each bolt (see diagram).

Slide logo plate into slots of both front legs. Attach logo plate to bottom of griddle body using small machine screws.

Hand-tighten all bolts before tightening with screwdriver or drill.

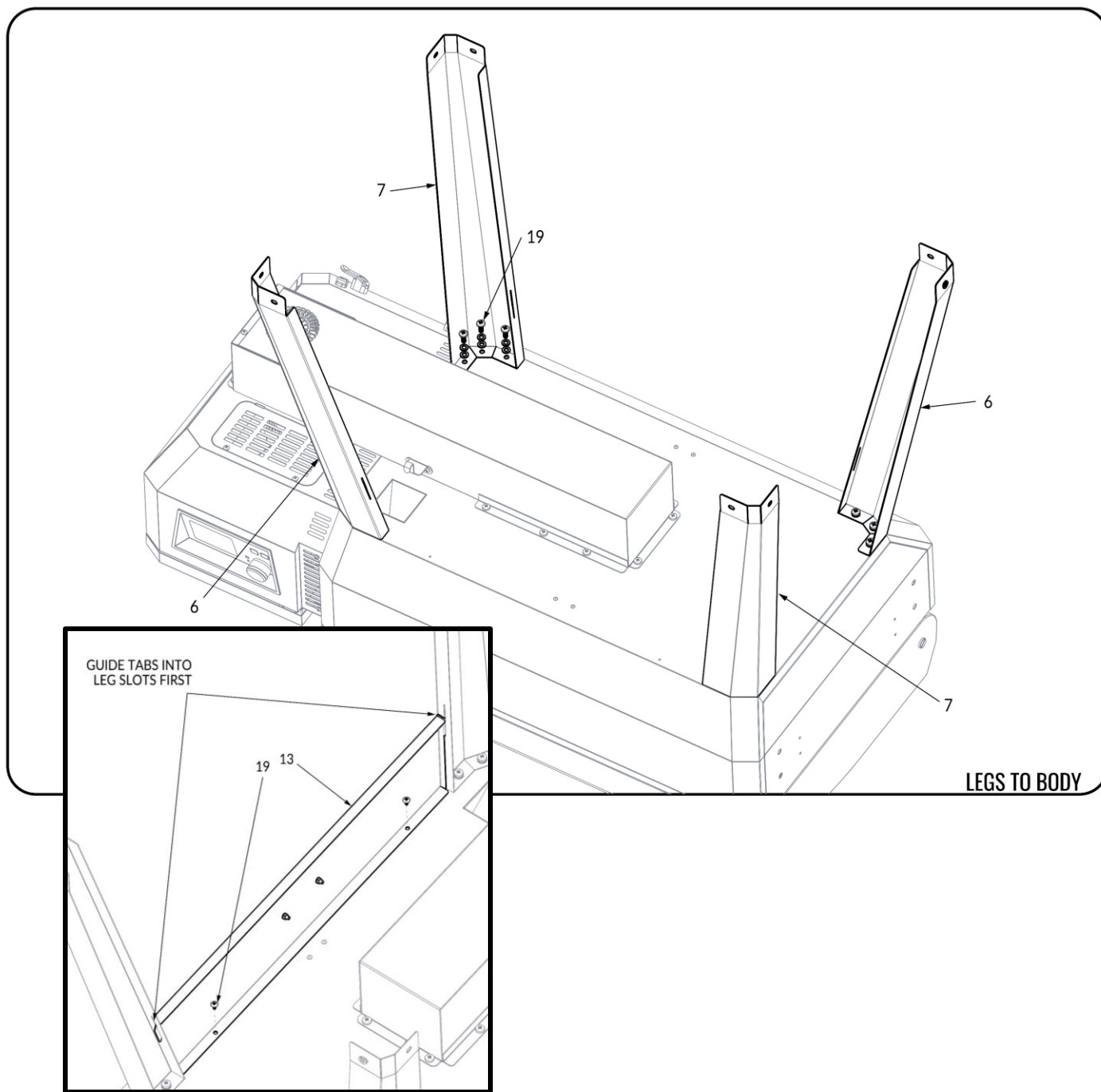

## Step 6: Attach Bottom Shelf

Ensure recteq logo is facing front of griddle and align shelf with feet of each leg.

Attach all four legs to bottom shelf using small bolt, lock washer, and flat washer.

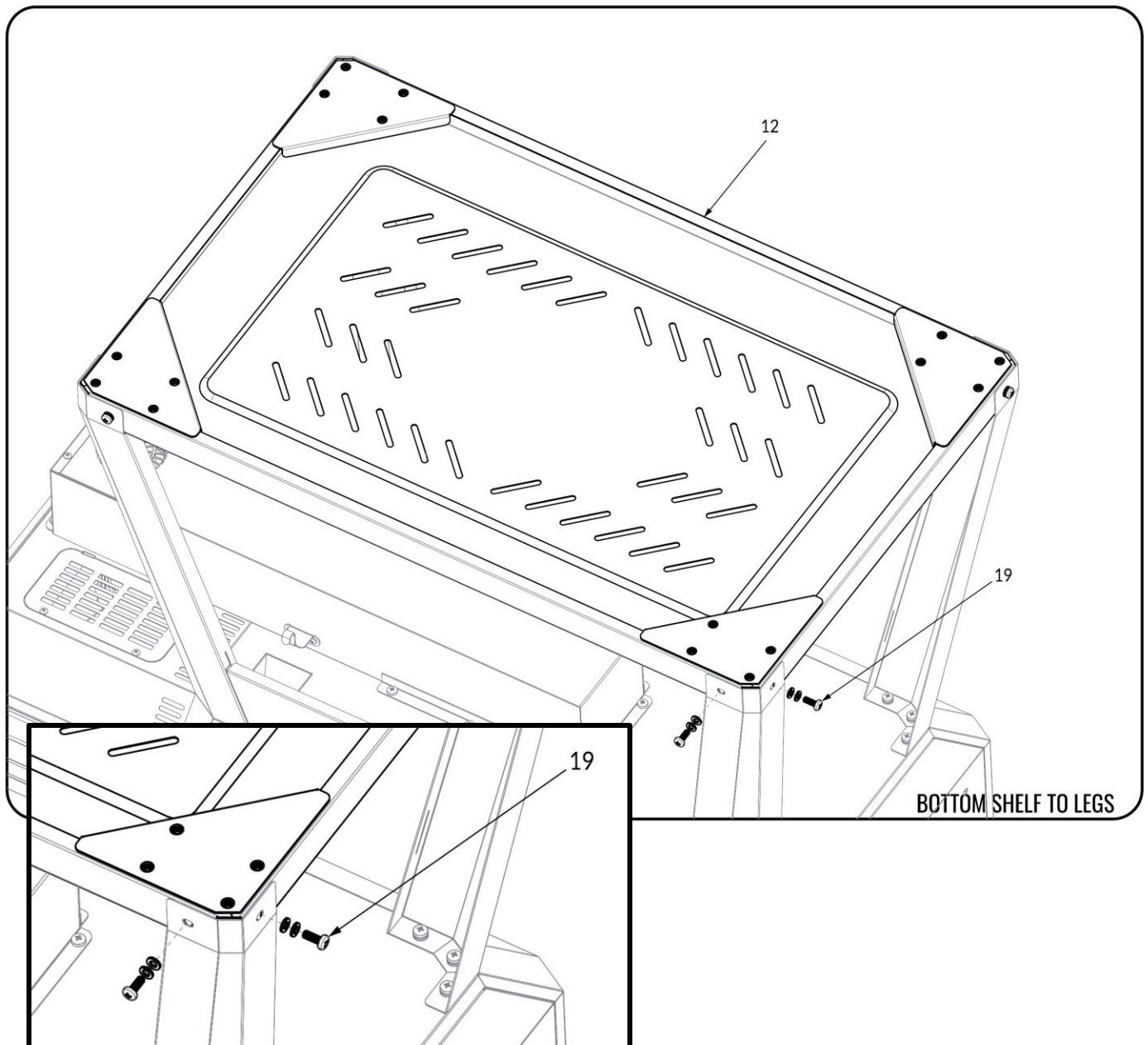

## Step 7: Attach Wheels

Attach both Caster wheels to the right side of the bottom shelf using medium bolt, lock washer, and flat washer.

Attach both Fixed wheels to the left side of the bottom shelf using medium bolt, lock washer, and flat washer.

\*note: caster & fixed wheels are interchangeable and can be installed on either side, based on personal preference.

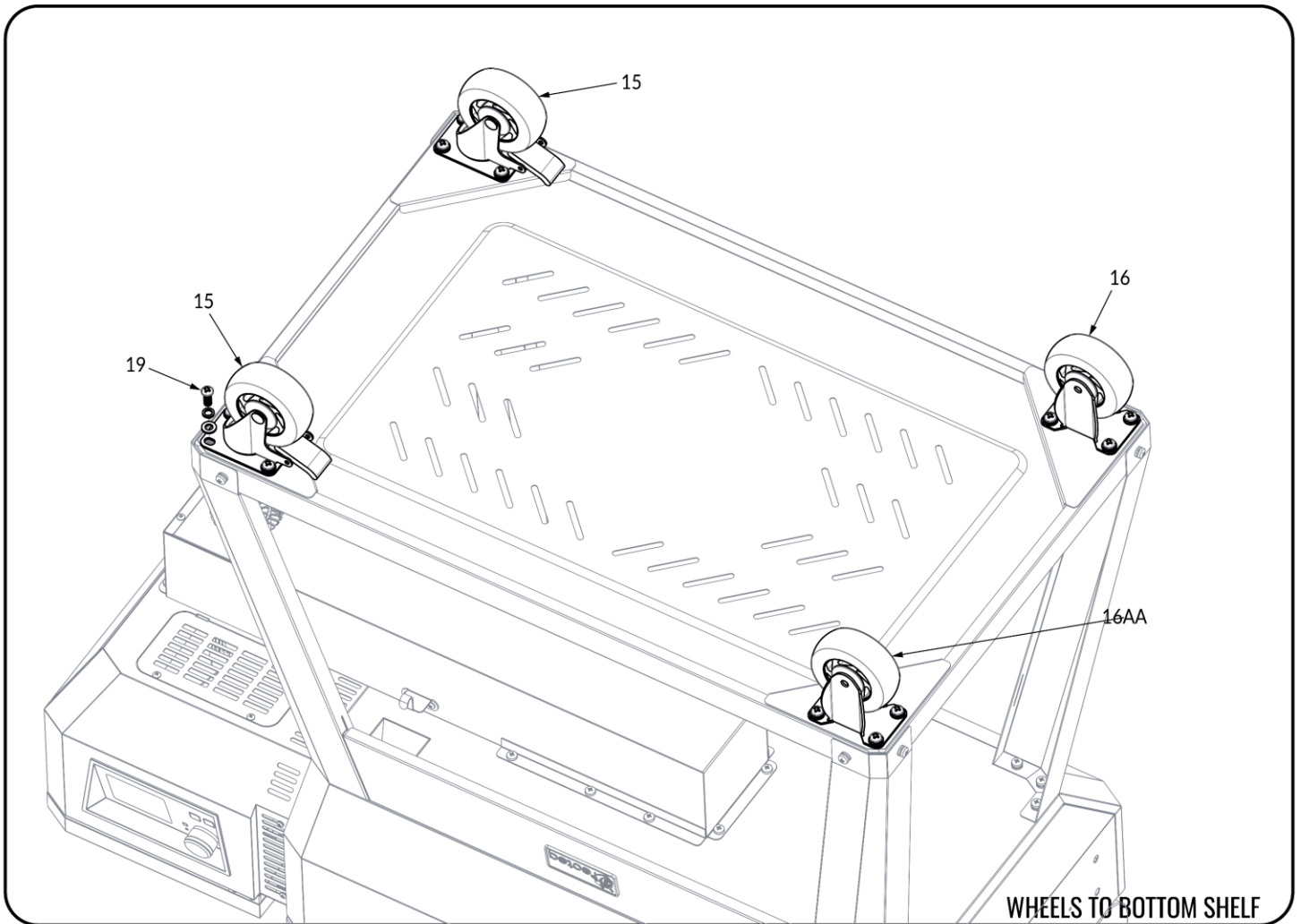

### Step 8: Stand Griddle Upright

With assistance (two-person lift recommended) and caster wheels locked, stand griddle upright.

### Step 9: Install Pull Bar

Attach pull bar to brackets using pre-installed bolts. Then attach pull bar to barrel using included hardware.

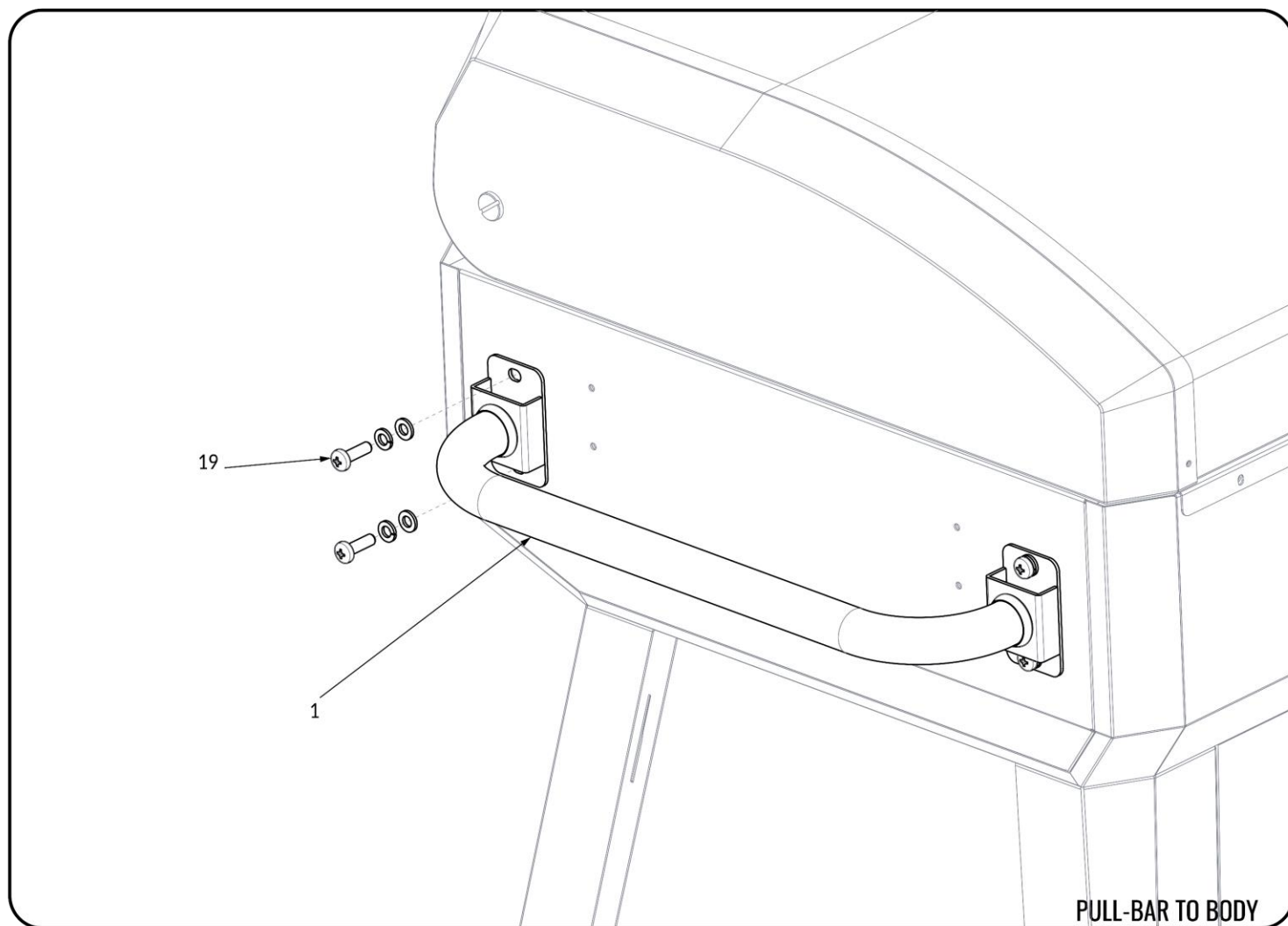

## Step 10: Install Bullhorn Handles

Attach bullhorn handles to lid using pre-installed bolts, flat washer, and lock washer. (Pads should be positioned between lid and handles)

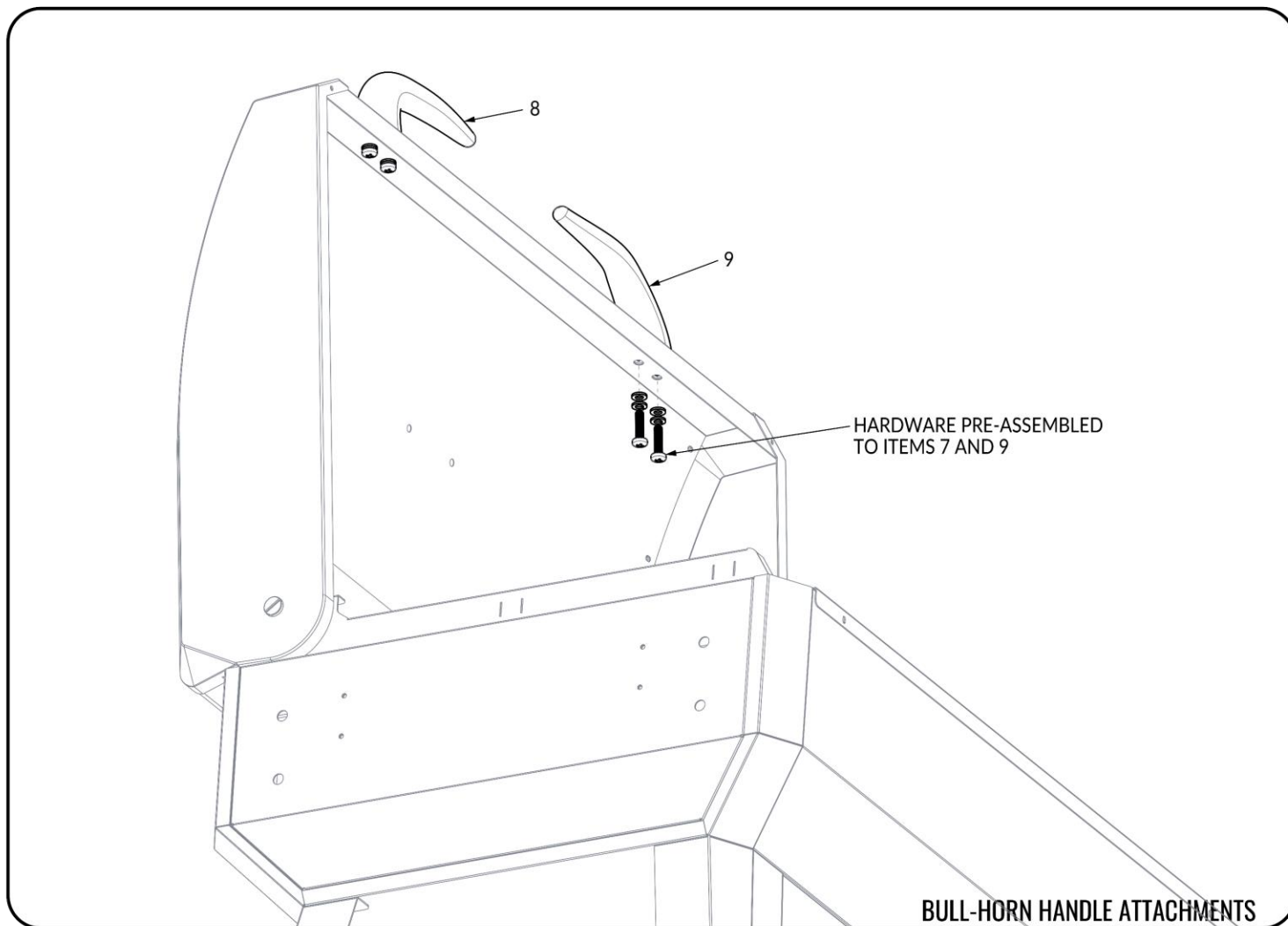

### Step 11: Attach Griddle Handles to Griddle

Attach griddle handles to griddle surface using bolt, flat washer, and lock washer. Ensure handles are attached on interior walls of griddle plate

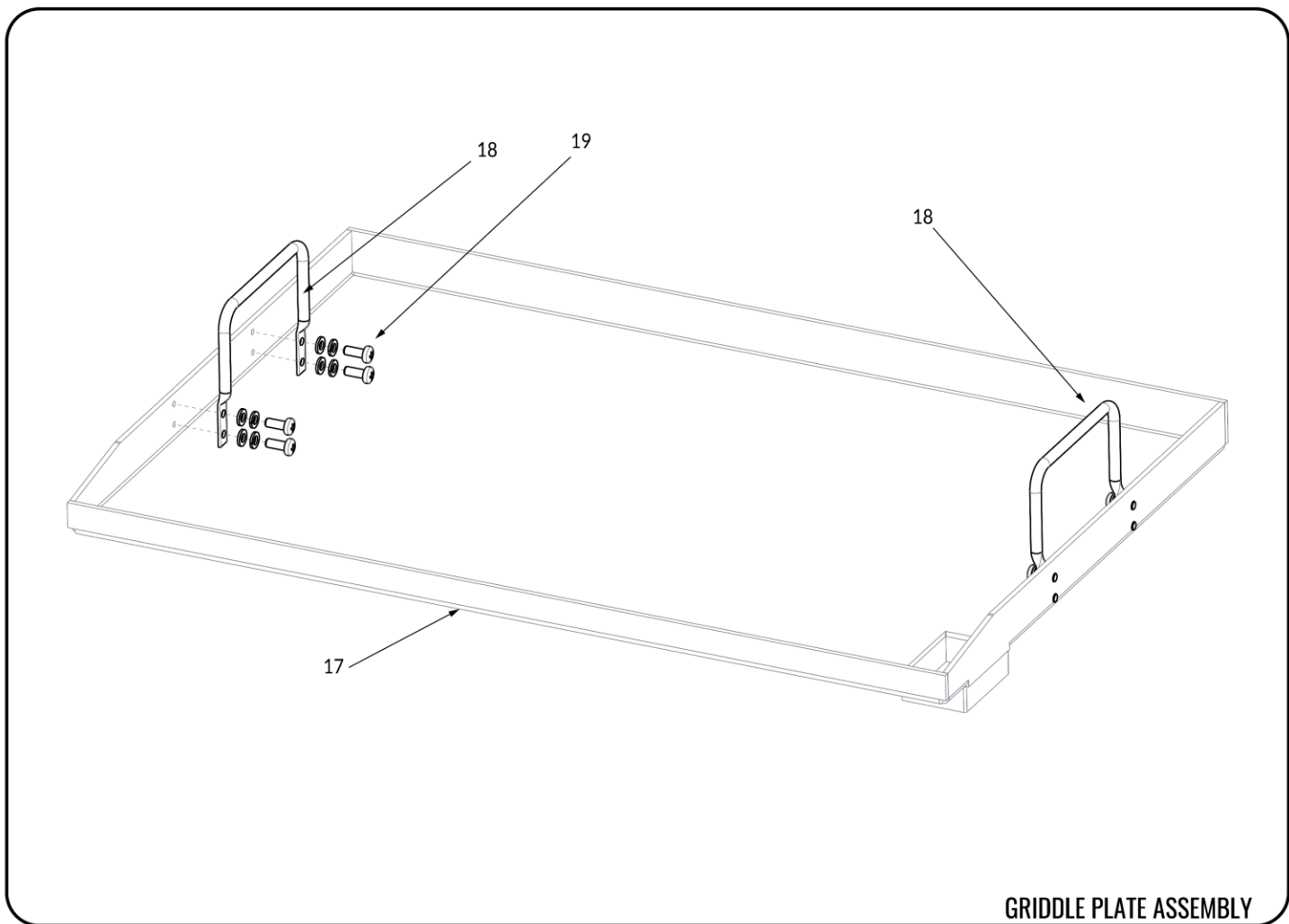

## Step 12: Install Deflector, Griddle, and Drip Bucket

Place deflector over firepot and, with grease spout in the front right, insert the griddle surface into place. Underneath grease spout, hang the drip bucket from clip attached to it.

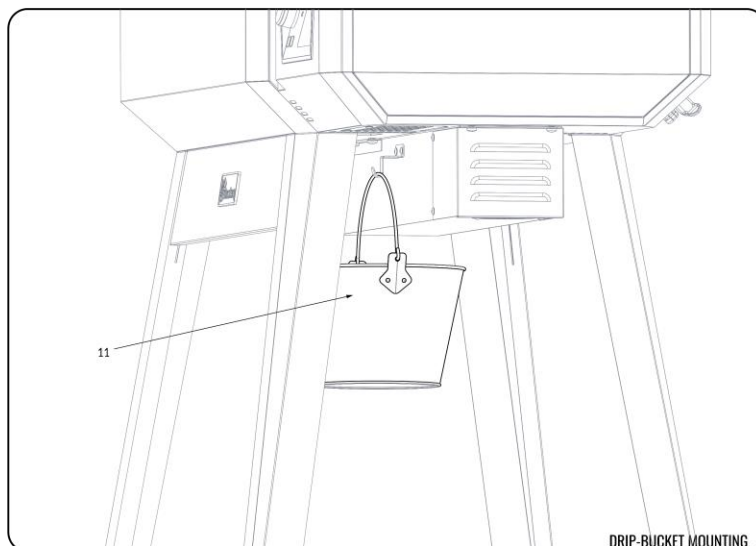
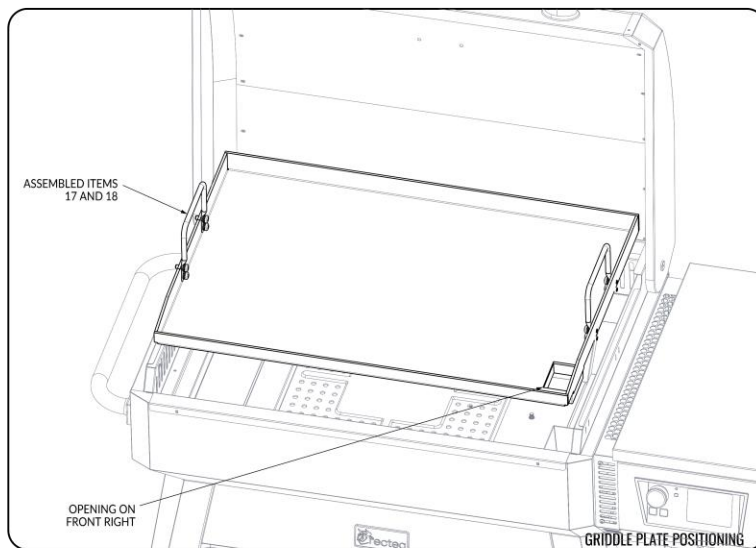
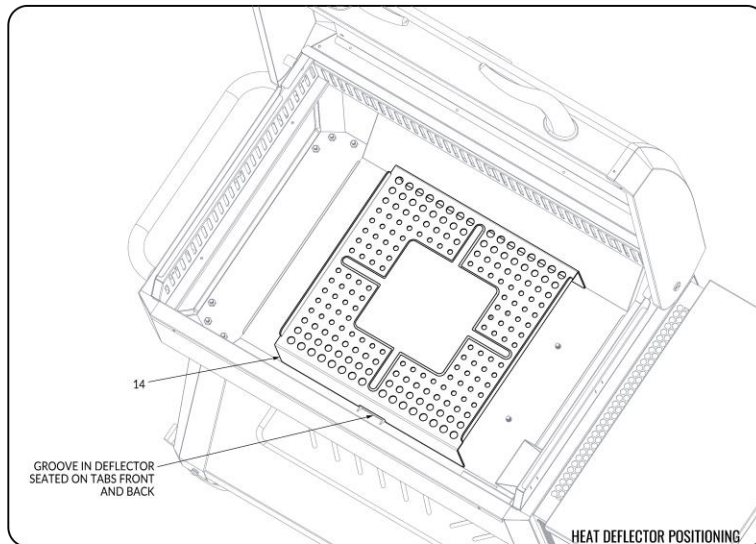

## INITIAL SETUP PROCEDURE

Before cooking for the first time, we recommend you remove the griddle and wash with mild soap and water. Fill your hopper at least halfway and place 1/4 cup of pellets in the firepot. Reinstall the deflector and griddle and set controller to Med. Once the griddle reaches ~400 °F, let it run with the lid down for 1 hour. This will provide a final cure and remove any residue that may have accumulated during manufacturing and shipping. After this initial burn, your griddle is ready for cooking.

Note: The griddle surface is made from cold rolled carbon steel and expansion and contraction naturally occurs. Minor warping may occur during initial heating cycles, but the griddle surface will relax. Should you experience this issue, rest assured that it will cease within the first 5-10 heating cycles.

## OPERATING YOUR GRIDDLE

DO NOT MANUALLY FILL YOUR FIREPOT WITH PELLETS.

DO NOT OVERFIRE OR ATTEMPT TO ACCELERATE THE NATURAL LIGHTING SEQUENCE OF YOUR GRIDDLE.

Press power button to turn griddle on and adjust temperature knob to desired temperature.

- Turning the griddle ON activates the automatic startup mode and illuminates the digital readout.
- If your griddle fails to light itself within 30 minutes of startup, the Smart Grill Technology™ processor will turn the griddle off and display ER-2 on the screen.
- Pressing the power button again activates the shut-down mode of your griddle. If actual temperature is below 160 °F, pressing the power button will simply turn the griddle off.
- When the power button is used to shut down your griddle, the Smart Grill Technology™ processor will stop adding pellets to the fire pot and the fan will continue running to completely burn the pellets remaining in the fire pot. During this cooling process, the display screen will display FAN. Shortly thereafter, the display screen will change to display AUG - this will push out any embers left in the auger tube into the fire pot

Temperature Control Knob: Turn knob to select computer-maintained temperature

**Temperature settings: LO and FUL**

**LOW: Low, the controller will heat your griddle to 300 °F.**

**LoM: Low-medium, the controller will heat your griddle to 350 °F.**

**MEd: Medium, the controller will heat your griddle to 400 °F.**

**MHI: Medium high, the controller will heat your griddle to 450 °F.**

**HI: High, the controller will heat your griddle to 500 °F.**

**FUL: FUL will display as set temperature when knob is turned clockwise beyond HI.**

**Griddle will feed pellets to the fire at 100% of auger capacity. This will produce the highest temperature possible, given environmental conditions/type of pellets used.**

## OPERATING YOUR GRIDDLE

**Settings Button:** Press and hold the settings button to access the adjustable parameters menu. Short presses of the settings button will scroll through the adjustable parameters. Pressing and holding the settings button will exit the adjustable parameters menu.

**Test Mode:** With griddle OFF, press and hold the Settings Button to enter the Adjustable Parameters Menu. Enter Test Mode from either of the five screens AUG, OFS, PrA, PrB, or rSt by pressing the Power Button. Each additional press of the Power Button will advance you through the 8 Test Mode screens. The last screen is the BYE screen. While on the BYE screen, press the Settings Button to return to the adjustable parameters screen, then press and hold the Settings Button and your griddle's controller will return to the OFF state.

### Adjustable Parameter 1

AUG	10
-----	----

**Adjustable Parameter 1: Min Feed Rate -** Min Feed Rate is the minimum rate that the auger is allowed to feed fuel to the fire pot, regardless of Set Point. Decreasing the value will allow the griddle to achieve lower temperatures but will increase the risk of flame-outs. Increasing the value will prevent losing fire but will limit your ability to maintain low temperatures on hot, sunny days. *Note: Changing this does not change the auger speed. The auger speed is constant.*

### Adjustable Parameter 2

OFS	0
-----	---

Turning the Temperature Control Knob clockwise will increase, and turning counterclockwise decrease, the value within the range of 5 - 250.

**Adjustable Parameter 2: Temperature Offset -** Your griddle has been precisely calibrated at our facility, but the Temperature Offset allows you to customize how your controller operates. Should you choose to rely on a secondary temperature probe, you can use the following process to recalibrate your Smart Grill Technology Controller.

### Adjustable Parameter

*Due to varying qualities of pellet brands, we give you the ability to adjust your minimum feed rate downward in the event that your griddle is running hot at lower temperatures. However, if you experience a sudden loss, followed by an immediate increase in griddle temperature, then your griddle has experienced a flame out and will automatically relight. This signifies that your minimum feed rate was adjusted too low and needs to be increased.*

## TEST MODE

VEr XXX

VEr                      ###

To enter test mode: Press and hold Settings for 3 seconds - Press Power repeatedly until you see AUG.

VEr XXX displays current software version.

Screen 5-1

5-1                      AUG

Screen 5-1 is test mode for your griddle's auger motor. You should be able to look in your griddle's firepot and see the end of the auger turning very slowly.

Screen 5-2 is test mode for your griddle's ignition system. You should be able to look into the firepot and see your igniter begin to glow within a few minutes.

**DO NOT TOUCH THE IGNITER.**

Screen 5-3

5-2                      IGN

0

Screen 5-3 is test mode for your griddle's blower fan. You should be able to hear the fan blowing.

Screen 5-3

5-3                      FAN

0

Screen 5-4 is test mode for your griddle's control knob. You can turn the knob to see the 000 value increase and decrease accordingly.

Screen 5-4

5-4                      NOb

000

Screen 5-5 is test mode for your griddle's temperature sensor and Probe A / Probe B. You can see the temperature values for each displayed on the screen (a value of - - - means the probe is not plugged in or the griddle's sensor is not connected).

Screen 5-6 is an internal quality control screen that has no function for the user.

Screen 5-5

5-5                      Actual  
85° F  
Probe A                      Probe B

Screen BYE is the final screen of test mode. Pressing the power button again will return you to Screen 5-1. Pressing the settings button will return you to the Settings Menu, at which time you can hold the Settings Button to exit Settings Menu and get back to a blank screen.

Screen 5-6

5-6                      UF1

Screen BYE

BYE

## SHUTTING OFF GRIDDLE

When you are done cooking, simply press the power button. The blower fan will run continuously and will shut off on its own. Then the auger will feed pellets to conclude the shut-down process. This pushes any smoldering pellets in the auger tube into the firepot where they can safely burn out on their own. Your griddle will continue to smoke after cool down is complete. This is normal as the remaining pellets are burning out. It's extremely important to keep the lid closed during this process. Do not move until the griddle is fully cooled.

## TIPS, TRICKS, AND TEMPS

### Preheating

It is important to allow your griddle to preheat to achieve your desired cooking temperature before cooking. This allows the entire griddle to heat up and quickly return to your desired temperature once your food is introduced. If you do not allow the griddle to preheat, you will find that it takes a longer period of time to bring both the griddle and food to your desired cooking temperature. It is important to leave the lid closed during preheating.

### Pellet Information

STORE PELLETS IN A DRY SPACE – AWAY FROM FLAMMABLE MATERIALS AND HEATING SOURCES

USE ONLY WOOD PELLET FUEL SPECIFIED FOR COOKING. DO NOT USE PELLET FUEL LABELED AS HAVING ADDITIVES

Premium hardwood pellets contain approximately 8,200 BTUs of heat per pound and leave less than 1% ash residue. Pellets should be stored in a dry area, as wet pellets will swell and turn back into sawdust. For the best results, always use premium hardwood pellets in your griddle. The use of grades other than premium hardwood pellets may result in temperature variations, uneven cooking, and poor results. Remember, pellets do not contain preservatives and will deteriorate over time.

Caution: Some wood pellets produced for heating fuel have a high content of softwood which can include pitch and should not be used for cooking. Always check with the pellet manufacturer to ensure that you are cooking with a premium, 100% hardwood pellet.

## TIPS, TRICKS, AND TEMPS

- Always use griddle on a level surface and lock/secure wheels.
- Check and clean fire pot regularly; this will ensure proper ignition and heat output.
- Not all pellets are created equal; always use dry and fresh pellets.
- Always store pellets in a dry area.
- Get to know your griddle and keep good cooking notes. This will help with consistency.
- Practice makes perfect.
- Always allow your meat to rest before serving.
- Always keep your cooking area clean.
- Wind can lower your griddle temperature.
- Always preheat griddle to desired temperature before use.
- Wipe off cooking surfaces before preheating; dirt and food stains can cook into surfaces.
- Always check pellet hopper for debris and remove excess pellet dust as needed.
- Foods cooked in pans or containers will require more time than foods cooked directly on griddle surface.
- Know your food's internal temperature.
- Use long handled tongs and spatulas for turning meats; do not use plastic utensils.
- Do not use accessories not specified for use with this appliance.
- Injecting, mopping, and spritzing are great ways to keep meat from drying out.
- When going low and slow, plan for your meats to stall; larger pieces of meat tend to take longer from 160° F-180° F. Be patient.
- Never unplug your griddle to turn it off.
- **When not in use, unplug and cover** with a recteq Premium Griddle Cover.
- Use only compatible meat probes with your recteq controller.

## TEMPERATURES

Remember, you can't tell whether meat is safely cooked by looking at it. Any cooked, uncured red meats (including pork) can be pink, even when the meat has reached a safe internal temperature.

After you remove the meat from your griddle, allow it to rest.

- Hot foods should be held at 140° F or warmer.
- Cold foods should be held at 40° F or colder.
- Perishable foods should not be left out for more than 2 hours at room temperature; 1 hour when the temperature is above 90° F.
- Always follow food safety guidelines provided by the USDA.

## MAINTENANCE & CLEANING

- CLEAN YOUR FIRE POT EVERY 3-5 COOKS OR AFTER EVERY 16 HOURS OF COOKING TIME, TO ENSURE PROPER AIRFLOW.
- PERIODICALLY CLEAN OUT VENT AT REAR OF LID TO ENSURE PROPER AIRFLOW AND MAXIMUM PERFORMANCE.
- DISPOSAL OF ASHES - ASHES SHOULD BE PLACED IN A METAL CONTAINER WITH A TIGHT-FITTING LID. THE CLOSED CONTAINER OF ASHES SHOULD BE PLACED ON A NONCOMBUSTIBLE FLOOR OR ON THE GROUND, WELL AWAY FROM ALL COMBUSTIBLE MATERIALS, PENDING FINAL DISPOSAL. IF THE ASHES ARE DISPOSED OF BY BURIAL IN SOIL OR OTHERWISE LOCALLY DISPERSED, THEY SHOULD BE RETAINED IN THE CLOSED CONTAINER UNTIL ALL CINDERS HAVE THOROUGHLY COOLED.
- Use a scraper or brush to clean your griddle and warming rack after every cook to provide years of trouble-free use.  
*Note: Make sure that no bristles have shed onto the cooking surfaces.*
- Use a mild soap and water to clean the exterior of your griddle. AVOID USING CAUSTIC CLEANERS! ie: ajax, comet, etc.
- If left in an exposed area, keep your griddle covered and unplugged when not in use.
- **Never let your pellets get wet; they will swell and jam your auger.**
- If griddle is not used for 6 weeks or more, it is advised to remove all pellets from hopper.
- Remove pots and pans while the operating appliance is unattended, to reduce the risk of fire.

Never store the griddle in a small space or place in a vehicle unless completely cool and fire is verified as extinguished. Never move the griddle while it is still hot. Never move the griddle without assistance.

Clean the ash from the interior of your griddle, fire pot, and hopper every 5-6 bags of pellets – a shop vac is an ideal tool for this job. It also helps to leave a thin layer of ash on the bottom of the barrel for insulation.

**WARNING:** Always wait at least 12 hours after cooking to remove ash from your griddle!

**Disposal of grease should comply with any and all local laws, rules, and ordinances**

## TROUBLESHOOTING

We pride ourselves on our griddles, accessories, and on our commitment to serve you. Please consult the chart below to help resolve issues you may encounter. Also, please don't hesitate to contact us with any issues.

(706) 922-0890

Issue	Potential Cause	Solution
Griddle will not light/turn on	Power	Make sure power is plugged into working GFCI outlet, and outlet is not tripped. Unplug griddle and check for blown fuse; refer to controller schematic on page 23.
	Fuse	Replace fuse manually and try again. Call Customer Service or visit recteq.com if problem persists.
	Igniter	Remove griddle and heat deflector and visually inspect fire pot and if after 10 minutes: <ul style="list-style-type: none"> <li>•your pellets are feeding</li> <li>•your blower fan is running</li> <li>•your griddle is still not lighting</li> </ul> Then your igniter rod may need to be replaced. Call Customer Service.
	Auger Motor	Remove griddle and heat deflector; visually inspect auger turning in the fire pot. (Note: the auger turns very slowly) If auger is not turning, you may have an obstruction in your hopper. Clean out pellets and try again. If problem persists, your auger motor may need to be replaced. Call Customer Service.
	Control Board	UNPLUG GRIDDLE. Check to make sure the fuse is intact and has not blown. Check for any loose wire connections. If any wires have become detached, refer to controller schematic.

Issue	Potential Cause	Solution
Griddle is smoking excessively/ smoke is discolored	Pellet quality/age	Inspect pellets; ensure that pellets are dry and have not broken down into sawdust. If problem persists, remove pellets from the hopper and clean ash from your firepot, then replace with fresh dry pellets.
	Excess ash in fire pot	Check the burn pot for ash and clean as necessary (it's advised to clean fire pot every 3-5 uses).
	Blower fan	Unplug griddle. Remove access panel; visually inspect blower fan for any obstructions, loose connections, bugs, etc. Remove obstructions. Power griddle on. If problem persists, unplug griddle. Spin fan manually for several revolutions. Plug griddle back in. If problem persists, your blower fan may need to be replaced. Call customer service.
Griddle will not heat up to or maintain proper temp	Pellet quality/age	Inspect pellets; ensure that pellets are dry and have not broken down into sawdust. If problem persists, remove pellets from the hopper and clean ash from your firepot, then replace with clean dry pellets.
	Insufficient airflow	Check firepot/smokestack/vents for any obstructions/ ash accumulation.
	Excess ash in fire pot	Check fire pot for ash and clear as necessary.
Fire continues to go out	Pellet quality/age	Inspect pellets; ensure that pellets are dry and have not broken down into sawdust. If problem persists, remove pellets from the hopper and clean ash from your firepot, then replace with clean dry pellets.
	Hopper obstruction	Unplug griddle. Remove pellets from hopper. Clean hopper of any obstructions or build up.
	Pellet Bridge	Excessively long pellets can catch on each other and cause pellets not to fall into the auger.

Issue	Potential Cause	Solution(s)
Pellets are not being delivered to fire pot	Hopper obstruction	Unplug griddle. Remove pellets from hopper. Clean hopper of any obstructions or build up.
	Auger Failure/Jam	Remove griddle and heat deflector plate; visually inspect auger turning in the fire pot. (Note: the auger turns very slowly) If auger is not turning, you may have an obstruction in your hopper. Clean out pellets and try again. If problem persists, your auger motor may need to be replaced. Call Customer Service.
Flare ups	Excessively greasy food while temperature setting is too high	Cook at 350°F or below when cooking excessively fatty foods.
Excessive grease/build up	Excessively greasy food	Cook at 350°F or below when cooking excessively fatty foods.
Smoke coming from hopper	Excess ash in firepot	Clean griddle interior.
	Pellet level very low in hopper	Add more pellets to hopper.
	Excess pellet dust lining auger tube causing burn back	Remove pellets from hopper and vacuum out hopper, auger tube, and fire pot.
ER-1	Power Failure	Make sure power is plugged into working GFCI outlet, and outlet is not tripped. Turn griddle off, then back on again to reset controller and clear code.
ER-2	Griddle hasn't ignited in over 30 minutes	Refer to "Griddle will not light/turn on" in Troubleshooting.
ER-3	RTD unplugged/griddle over heated	Check connection and let griddle cool. Turn off and back on to reset controller and clear code

## TROUBLESHOOTING

In case of igniter failure, you can start your SmokeStone manually:

1. Remove the griddle and heat deflector.
2. Clean out fire pot and place no more than 1/2 cup of pellets in the bottom. Add a small amount of solid fuel fire starter, such as those made from sawdust and wax, or use wood shavings.

*Tip: A paper towel, shredded cardboard, or shredded newspaper can work as a substitute.*

If you have a torch lighter, a fire starter is not needed.

3. Light the fire starter.
4. After the pellets are burning briskly, turn on your griddle. If your fire goes out, repeat steps 1-4.
5. If your fire stays lit, replace the heat deflector and griddle then close the lid.

Be careful not to touch the fire.

**CAUTION:** Do not use flammable liquids such as gasoline, gasoline-type lantern fuel, kerosene, charcoal lighter fluid, or similar liquids to start or freshen-up the fire! Keep all such liquids well away from the griddle while it is in use.

# WARRANTY

This limited warranty covers the SmokeStone 600 Wood Pellet Griddle manufactured by “recteq, LLC.” The SmokeStone carries a 4-year limited warranty from the date of purchase by the original owner against defects in material and workmanship when subjected to normal residential use. Limited warranty does not apply to paint, griddle cover, or damage caused from corrosion.

## Conditions of Limited Warranty

1. During the term of the limited warranty, recteq, LLC’s obligation shall be limited to replacement of covered, failed components. recteq will repair or replace parts returned to recteq, freight prepaid, if the part(s) are found by recteq to be defective upon examination. recteq shall not be liable for transportation charges, labor costs, or export duties.
2. recteq takes every precaution to utilize materials that retard rust including the use of high temperature paint and stainless steel where advisable. Even with these safeguards, the protective coatings can be compromised by various substances and conditions beyond recteq’s control. High temperatures, excessive humidity, chlorine, industrial fumes, fertilizers, lawn pesticides, and salt are some of the substances that can affect paint and metal coatings. For these reasons, the limited warranties DOES NOT COVER RUST OR OXIDATION FOR ANY REASON.
3. The warranty is based on residential use. Warranty coverage does not apply to products used in commercial applications.

## Exceptions to the Limited Warranty

There is no written or implied performance warranty on recteq, as the manufacturer has no control over the installation, operations, cleaning, maintenance or the type of fuel burned. This limited warranty will not apply nor will recteq assume responsibility if your product has not been installed, operated, cleaned, and maintained in strict accordance with the manufacturer’s instructions. The warranty does not cover damage or breakage due to misuse, improper handling, or modifications. NEITHER THE MANUFACTURER, NOR THE SUPPLIERS TO THE PURCHASER ACCEPTS RESPONSIBILITY, LEGAL OR OTHERWISE, FOR THE INCIDENTAL OR CONSEQUENTIAL DAMAGE TO THE PROPERTY OR PERSONS RESULTING FROM THE USE OF THIS PRODUCT. ANY WARRANTY IMPLIED BY LAW, INCLUDING BUT NOT LIMITED TO IMPLIED WARRANTIES OF MERCHANTABILITY OR FITNESS, SHALL BE LIMITED TO FOUR (4) YEARS FROM THE DATE OF ORIGINAL PURCHASE. WHETHER A CLAIM IS MADE AGAINST THE MANUFACTURER BASED ON THE BREACH OF THIS WARRANTY OR ANY OTHER TYPE OF WARRANTY EXPRESSED OR IMPLIED BY LAW, MANUFACTURER SHALL IN NO EVENT BE LIABLE FOR ANY SPECIAL, INDIRECT, CONSEQUENTIAL, OR OTHER DAMAGES OF ANY NATURE WHATSOEVER IN EXCESS OF THE ORIGINAL PURCHASE PRICE OF THIS PRODUCT. ALL WARRANTIES BY MANUFACTURER ARE SET FORTH HEREIN AND NO CLAIM SHALL BE MADE AGAINST MANUFACTURER ON ANY ORAL WARRANTY OR REPRESENTATION. Some states do not allow the exclusion or limitation of incidental or consequential damages, or limitations of implied warranties, so the limitations or exclusions set forth in this limited warranty may not apply to you. This limited warranty gives you specific legal rights and you may have other rights, which vary from state to state.

The limited warranty for four (4) years is in lieu of all other warranties expressed or implied, at law or otherwise, and recteq does not authorize any person or representative to assume for recteq any obligation or liability in connection with the sale of this product. This means that no warranties, either expressed or implied, are extended to persons who purchase the product from anyone other than recteq or an authorized recteq Distributor.

## Procedure for Warranty Service

Call recteq (706)922-0890 for repair or replacement of your covered parts. Be prepared to furnish the following information.

- Purchaser’s name, model, and serial number of griddle, and date of purchase.
- An accurate description of the problem.